

# FLUID MECHANICS

**Prashant S. Minz**



**AGRIMOON.COM**  
All About Agriculture...

# Fluid Mechanics

*Course Developer*

**Prashant S. Minz**



**AGRIMOON.COM**

*All About Agriculture...*

# Index

Lesson Name	Page No
<b>MODULE 1. FLUIDS MECHANICS</b>	
LESSON 1. INTRODUCTION TO FLUID MECHANICS	5-9
<b>MODULE 2. PROPERTIES OF FLUIDS</b>	
LESSON 2. FLUID	10-11
LESSON 3. PROPERTIES OF FLUID	12-20
<b>MODULE 3. PRESSURE AND ITS MEASUREMENT</b>	
LESSON 4. PRESSURE	21-26
LESSON 5. PRESSURE MEASUREMENT	27-30
<b>MODULE 4. PASCAL'S LAW</b>	
LESSON 6. PASCAL'S LAW	31-34
<b>MODULE 5. PRESSURE FORCES ON PLANE AND CURVED SURFACES</b>	
LESSON 7. PRESSURE FORCES ON PLANE SURFACES	35-38
<b>MODULE 6. BUOYANCY, METACENTRE AND METACENTRIC HEIGHT, CONDITION OF FLOATATION AND STABILITY OF SUBMERGED AND FLOATING BODIES</b>	
LESSON 8. BUOYANCY	39-43
LESSON 09. ARCHIMEDES' PRINCIPLE	44-45
<b>MODULE 7. KINEMATICS OF FLUID FLOW</b>	
LESSON 10. FLUID KINEMATICS	46-49
Lesson-11: FLOW VISUALIZATION	50-52
Lesson-12: FLOW PATTERNS	53-56
<b>MODULE 8: CIRCULATION AND VORTICITY</b>	
Lesson-13: CIRCULATION AND VORTICITY	57-62
<b>MODULE 9.</b>	
Lesson-14: FLOWNET	63-64
<b>MODULE 10.</b>	
Lesson-15: CONTINUITY EQUATION	65-67
<b>MODULE 11, 12. FLUID DYNAMICS</b>	
LESSON 16. DYNAMICS OF FLUID FLOW	68-71
LESSON 17. APPLICATIONS OF BERNOULLI'S EQUATION	72-76
LESSON 18. VENTURIMETER, ORIFICEMETER AND NOZZLE, SIPHON	77-78

FLOWRATE MEASUREMENT	
<b>MODULE 13. LAMINAR AND TURBULENT FLOW IN PIPES</b>	
LESSON 19. FLOW IN PIPES	79-81
LESSON 20. LAMINAR AND TURBULENT FLOW	82-86
<b>MODULE 14. GENERAL EQUATION FOR HEAD LOSS-DARCY EQUATION</b>	
LESSON 21. GENERAL EQUATION FOR HEAD LOSS-DARCY EQUATION	87-89
LESSON 22. EMPIRICAL EQUATIONS FOR FRICTION HEAD LOSS	90-92
<b>MODULE 15. MAJOR AND MINOR HYDRAULIC LOSSES THROUGH PIPES AND FITTING</b>	
LESSON 23. MAJOR AND MINOR HYDRAULIC LOSSES THROUGH PIPES AND FITTING	93-96
<b>MODULE 16. DIMENSIONAL ANALYSIS AND SIMILITUDE</b>	
LESSON 24. DIMENSIONAL ANALYSIS	97-100
LESSON 25. DIMENSIONAL HOMOGENEITY	101-105
<b>MODULE 17. INTRODUCTION TO FLUID MACHINERY</b>	
LESSON 26. INTRODUCTION TO FLUID MACHINERY	106-110

MODULE 1. FLUIDS MECHANICS

LESSON 1. INTRODUCTION TO FLUID MECHANICS

1. What is Fluid mechanics?

It is a physical science concerned with the behavior of fluid at (liquids, gases, and plasmas) rest and motion and the forces on them.

Fluid mechanics can be divided in to different sub branches as:

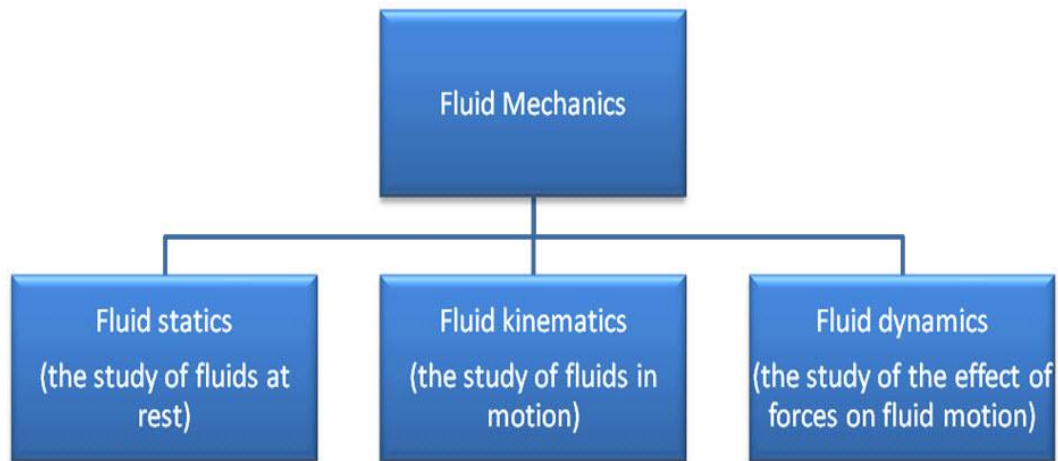

Examples:

(i) Flight of birds in air	
(ii) Cricket ball, spin & velocity	
(iii) Circulation of blood in veins	
(iv) Design of aero plane and ships	
(v) Oil& gas pipe lines	
(vi) Milk circulation in dairy plant	
(vii) Aseptic processing of fruit juice	

## Fluids Mechanics

- This study area deals with many and diversified problems such as: It is a branch of continuum mechanics, a subject which models matter without using the information that it is made out of atoms, that is, it models matter from a macroscopic viewpoint rather than from a microscopic view point. It is a branch of continuum mechanics, a subject which models matter without using the information that it is made out of atoms, that is, it models matter from a macroscopic viewpoint rather than from a microscopic viewpoint.
  - surface tension,
  - fluid statics,
  - flow in enclosed bodies, or flow round bodies (solid or otherwise),
  - flow stability, etc.
- It is a branch of continuum mechanics, a subject which models matter without using the information that it is made out of atoms, that is, it models matter from a macroscopic viewpoint rather than from a microscopic viewpoint.
- Fluid mechanics, especially fluid dynamics, is an active field of research with many unsolved or partly solved problems. Fluid mechanics can be mathematically complex. Sometimes it can best be solved by numerical methods, typically using computers.
- A modern discipline, called computational fluid dynamics (CFD), is devoted to this approach to solving fluid mechanics problems.
- Also taking advantage of the highly visual nature of fluid flow is particle image velocimetry, an experimental method for visualizing and analyzing fluid flow.

## 2. History of fluid mechanics

Published paper "On the Theories of Internal Friction of Fluids in Motion" and derived equations known as Navier-Stokes equations

### Archimedes (250 B.C.)



- Investigated fluid statics and buoyancy and formulated his famous law known now as the Archimedes' principle
- Generally considered to be the first major work on fluid mechanics.
- for example, larger tunnels built for a larger water supply

**Leonardo Da Vinci (1452-1519)**

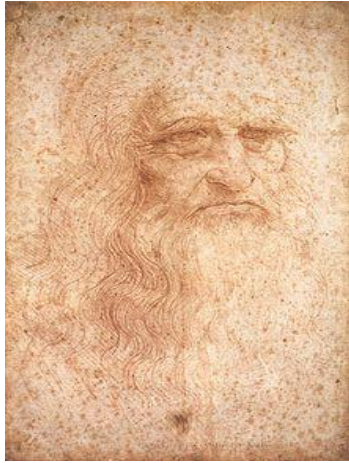

- The first progress in fluid mechanics
- He built the first chambered canal lock near Milan.
- He also made several attempts to study the flight (birds)
- Developed some concepts on the origin of the forces.

**Evangelista Torricelli (1608-1647)**



- Invented barometer

**Isaac Newton (1642-1727)**

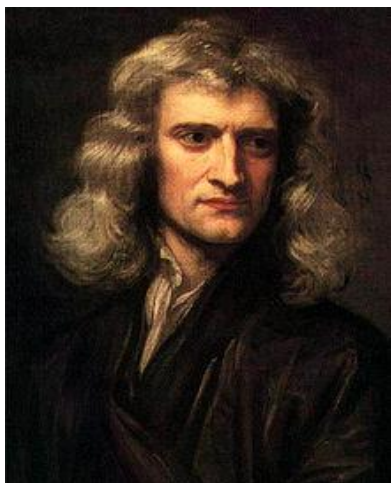

- Researched Viscosity

**Blaise Pascal (1623-1662)**



- Researched hydrostatics, formulated Pascal's law

**Daniel Bernoulli (1700 - 1782)**



- Started mathematical fluid dynamics
- Published "Hydrodynamica" and introduced word "hydrodynamics" to encompass various topics of fluid statics and dynamics

**Leonhard Euler (1707-1783)**



- Euler's equation of acceleration or motion.
- Studied motion of fluid under the action of external force



<p><b>Jean le Rond d'Alembert (1717-1783)</b></p> <p><b>Joseph Louis Lagrange (1736-1813)</b></p> <p><b>Pierre-Simon Laplace Siméon Denis Poisson</b></p>	<ul style="list-style-type: none"> <li>Analyzed inviscid flow</li> </ul>
<p><b>Jean Louis Marie Poiseuille (1799-1869)</b></p> <p><b>Gotthilf Hagen (1707-1884)</b></p>	<ul style="list-style-type: none"> <li>Explored viscous flow</li> </ul>
<p><b>Claude-Louis Navier (1785-1836)</b></p> <p><b>George Gabriel Stokes (1819-1903)</b></p>	<ul style="list-style-type: none"> <li>Published paper "On the Theories of Internal Friction of Fluids in Motion" and derived equations known as Navier-Stokes equations</li> </ul>
<p><b>Ludwig Prandtl (1875-1953),</b></p> <p><b>Theodore von Kármán (1881-1963)</b></p>	<ul style="list-style-type: none"> <li>Investigated boundary layers</li> </ul>
<p><b>Osborne Reynolds (1842-1912)</b></p> <p><b>Andrey Kolmogorov</b></p> <p><b>Geoffrey Ingram Taylor (1886-)</b></p>	<ul style="list-style-type: none"> <li>Advanced the understanding of fluid viscosity and turbulence</li> </ul>



MODULE 2. PROPERTIES OF FLUIDS

LESSON 2. FLUID

2. Fluid concept

With exception to solids, any other matters can be categorised as fluid. In microscopic point of view, this concept corresponds to loose or very loose bonding between molecules of liquid or gas, respectively.

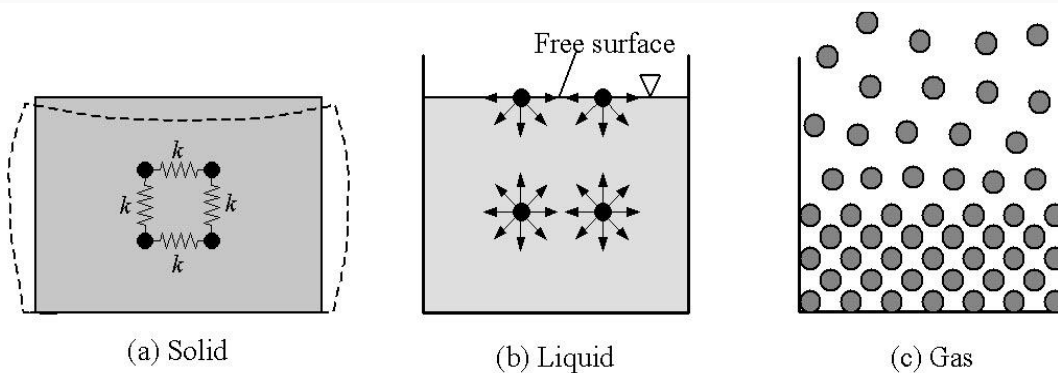

Figure 1. Comparison between Solids, Liquids and Gases

(For solid, imagine that the molecules can be fictitiously linked to each other with springs)

- In fluid, the molecules can move freely but are constrained through a traction force called cohesion. This force is interchangeable from one molecule to another.
- For gases, it is very weak which enables the gas to disintegrate and move away from its container.

For liquids, it is stronger which is sufficient enough to hold the molecule together and can withstand high compression, which is suitable for application as hydraulic fluid such as oil. On the surface, the cohesion forms a resultant force directed into the liquid region and the combination of cohesion forces between adjacent molecules from a tensioned membrane known as free surface

2.1. Distinction between Liquid & Gas is based on:

- Compressibility
- Molecular spacing

2.2. Definition of Fluid

## Fluids Mechanics

**Word fluid:** A substance having particles which readily change their relative position.

**Definition of Fluid:** A substance which deforms continuously under the action of shear stress, regardless of its magnitude.

### 2.3. Fluid continuum

Since the fluid flows continuously, any method and technique developed to analyse flow problems should take into consideration the continuity of the fluid. There are two types of approaches that can be used:

#### 2.3.1 Eulerian approach

Analysis is performed by defining a control volume to represent fluid domain which allows the fluid to flow across the volume. This approach is more appropriate to be used in fluid mechanics.

#### 2.3.2 Lagrangian approach

Analysis is performed by tracking down all motion parameters and deformation of a domain as it moves. This approach is more suitable and widely used for particle and solid mechanics.

The fluid behaviour in which its properties are continuous field variables, either scalar or vector, throughout the control volume is known as continuum. Strong inter molecular cohesive force compel the fluid to behave as a continuous mass.

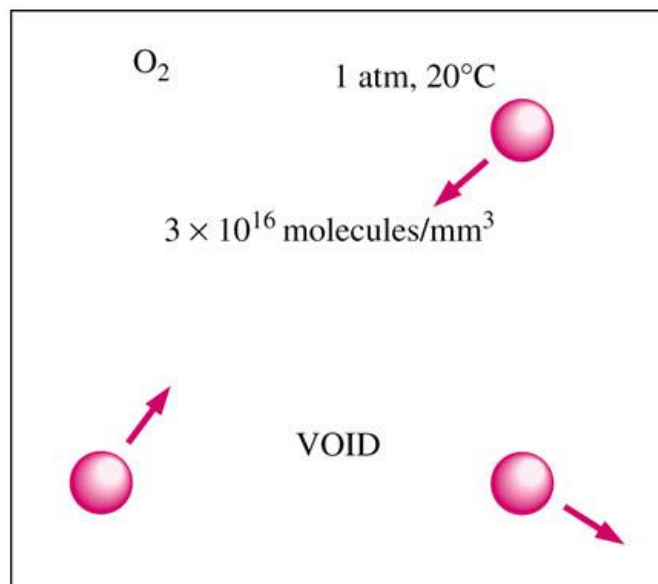

From this concept, several fluid or flow definitions can be made as follows:

Steady state y a function of position  $(x,y,z)$  but not time  $t$ :

$$r = r(x,y,z), V = V(x,y,z)$$

An example is the velocity of a steady flow of a river where the upstream and downstream velocities are different but their values does not change through time.

LESSON 3. PROPERTIES OF FLUID

3.1 FLUID PROPERTIES

3.1 SHEAR STRESS

### Fluid Deformation between Parallel Plates

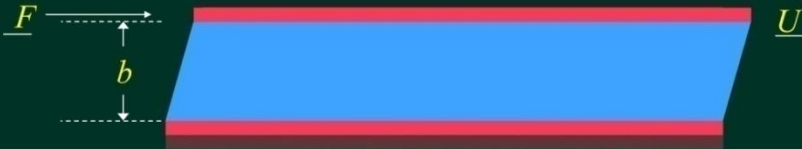

Side view

Force  $F$  causes the top plate to have velocity  $U$ .  
 What other parameters control how much force is required to get a desired velocity?

- Distance between plates ( $b$ )
- Area of plates ( $A$ )
- Viscosity!

### Shear Stress

$$F = \mu \frac{AU}{b} \qquad \mu = \frac{Ft}{AU} \quad \text{dimension of} \quad \left[ \frac{\text{N} \cdot \text{s}}{\text{m}^2} \right]$$

$$\tau = \frac{F}{A} \qquad \text{Tangential force per unit area} \quad \left[ \frac{\text{N}}{\text{m}^2} \right]$$

$$\tau = \mu \frac{U}{b} \qquad \frac{U}{b} \quad \text{Rate of angular deformation} \quad \left[ \frac{1}{\text{s}} \right]$$

$$\tau = \mu \frac{du}{dy} \qquad \text{change in velocity with respect to distance}$$

rate of shear

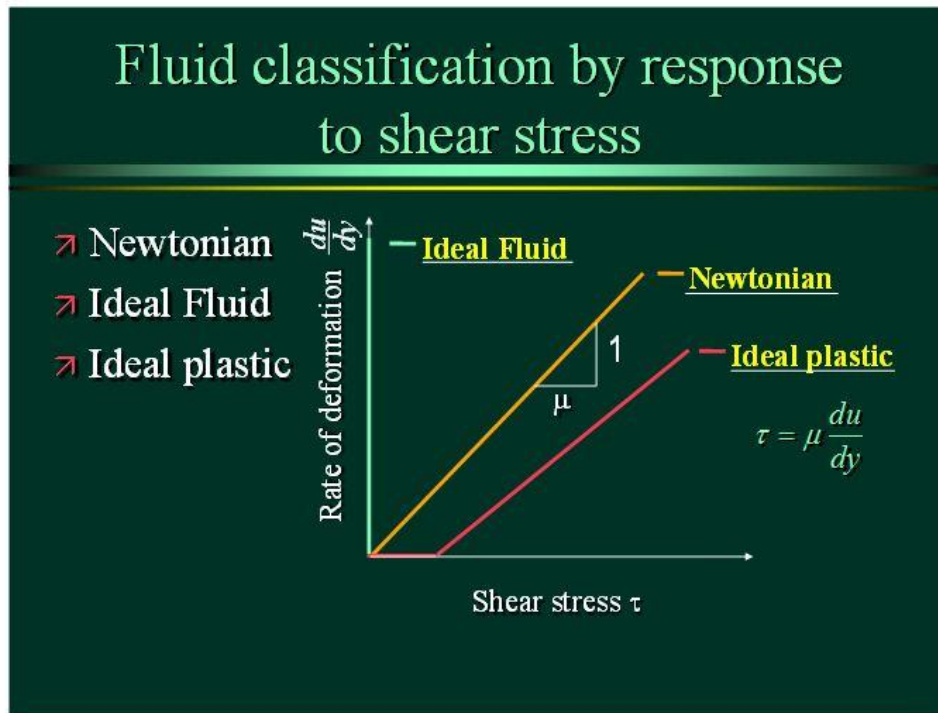

### 3.1.2 Density of a fluid ( $\rho$ )

Definition: mass per unit volume,

slightly affected by changes in temperature and pressure.

$$= \text{mass/volume} = m/v$$

Units:  $\text{kg/m}^3$

Typical values:

Water =  $1000 \text{ kg/m}^3$ ; Air =  $1.23 \text{ kg/m}^3$

- Viscosity,  $\mu$ , is a measure of resistance to fluid flow as a result of intermolecular cohesion. In other words, viscosity can be seen as internal friction to fluid motion which can then lead to energy loss.
- Different fluids deform at different rates under the same shear stress. The ease with which a fluid pours is an indication of its viscosity. Fluid with a high viscosity such as syrup deforms more slowly than fluid with a low viscosity such as water. The viscosity is also known as dynamic viscosity.
- **Units:**  $\text{N}\cdot\text{s}/\text{m}^2$  or  $\text{kg}/\text{m}\cdot\text{s}$
- **Typical values:**  
 Water =  $1.14 \times 10^{-3} \text{ kg}/\text{m}\cdot\text{s}$ ;  
 Air =  $1.78 \times 10^{-5} \text{ kg}/\text{m}\cdot\text{s}$

3.1.3 Viscosity ( $\mu$ )

- Viscosity,  $\mu$ , is a measure of resistance to fluid flow as a result of intermolecular cohesion. In other words, viscosity can be seen as internal friction to fluid motion which can then lead to energy loss.

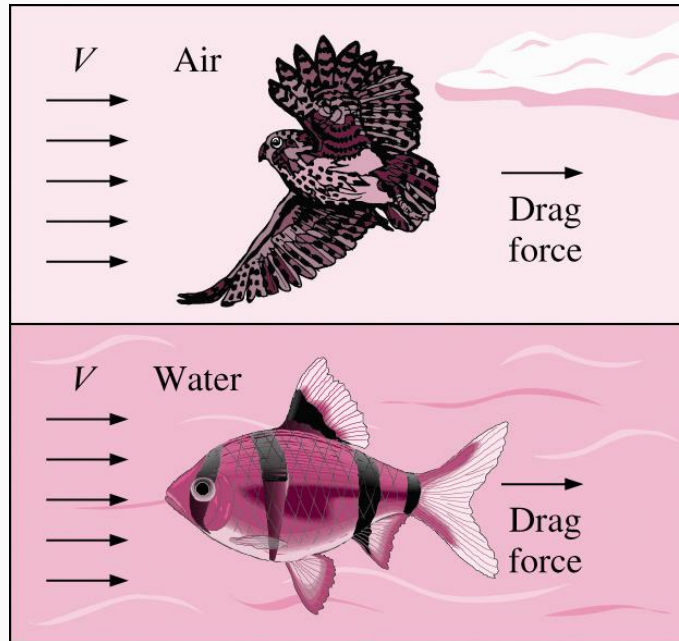

- Different fluids deform at different rates under the same shear stress. The ease with which a fluid pours is an indication of its viscosity. Fluid with a high viscosity such as syrup deforms more slowly than fluid with a low viscosity such as water. The viscosity is also known as dynamic viscosity.
- **Units:** N.s/m<sup>2</sup> or kg/m/s
- **Typical values:**

Water =  $1.14 \times 10^{-3}$  kg/m/s;

Air =  $1.78 \times 10^{-5}$  kg/m/s

3.1.4 Newtonian and Non-Newtonian Fluid

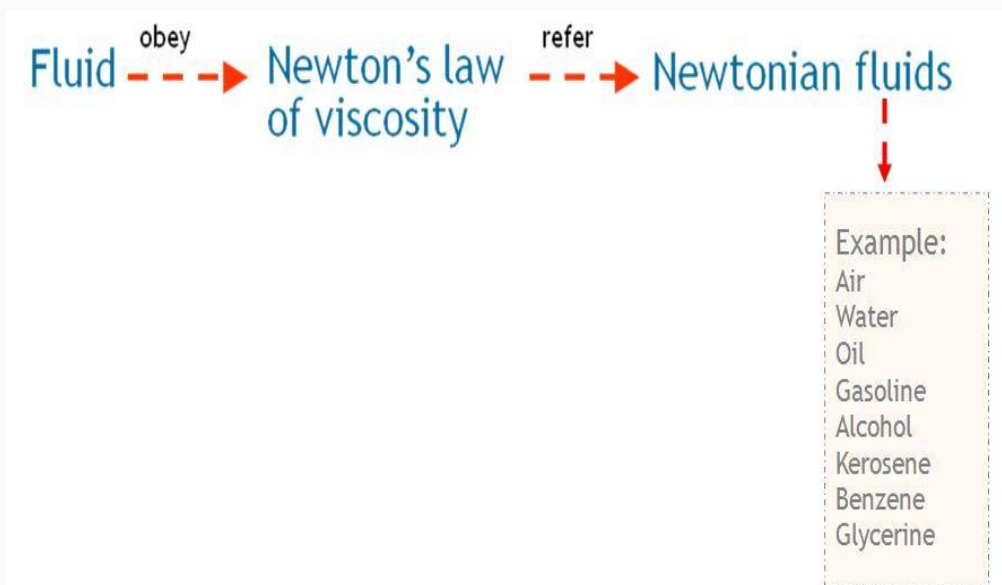

## Fluids Mechanics

Newton's law of viscosity is given by;

$$\tau = \mu \frac{du}{dy}$$

$\tau$  = shear stress

$\mu$  = viscosity of fluid

$du/dy$  = shear rate, rate of strain or velocity gradient

- The viscosity  $\mu$  is a function only of the condition of the fluid, particularly its temperature.
- The magnitude of the velocity gradient ( $du/dy$ ) has no effect on the magnitude of  $\mu$ .



- The viscosity of the non-Newtonian fluid is dependent on the velocity gradient as well as the condition of the fluid.

## Newtonian Fluids

- a linear relationship between shear stress and the velocity gradient (rate of shear),
- the slope is constant
- the viscosity is constant

## Non-Newtonian Fluids

slope of the curves for non-Newtonian fluids varies

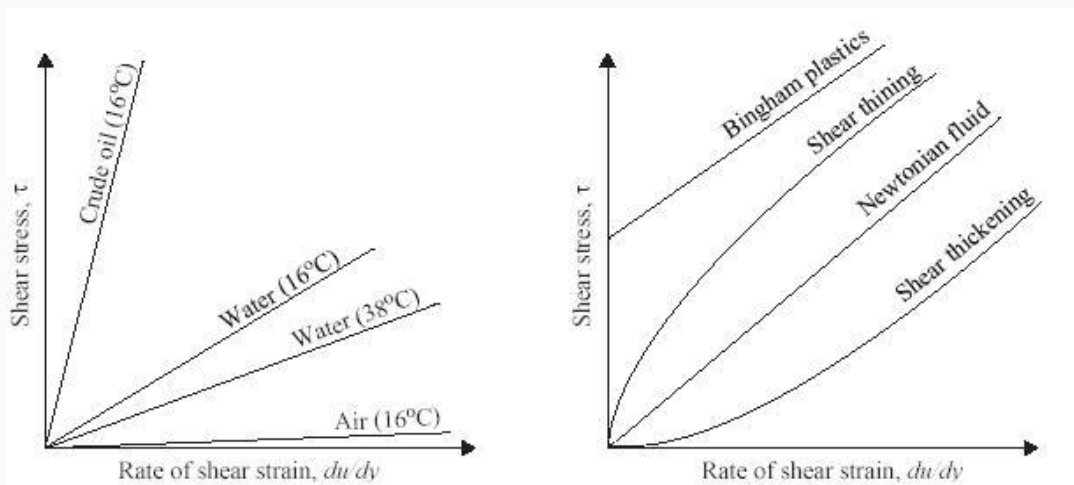

**Figure 1.5:** Newtonian and non-Newtonian Fluids

## Fluids Mechanics

If the gradient  $m$  is constant, the fluid is termed as Newtonian fluid. Otherwise, it is known as non-Newtonian fluid. Fig. 1.5 shows several Newtonian and non-Newtonian fluids.

### 3.1.5 Kinematic viscosity, $\nu$

Definition: is the ratio of the viscosity to the density;

$$\nu = \frac{\mu}{\rho}$$

- will be found to be important in cases in which significant viscous and gravitational forces exist.

**Units:**  $\text{m}^2/\text{s}$

**Typical values:**

Water =  $1.14 \times 10^{-6} \text{ m}^2/\text{s}$ ;      Air =  $1.46 \times 10^{-5} \text{ m}^2/\text{s}$ ;

In general,

- viscosity of liquids decrease with increase in temperature, whereas
- viscosity of gases increases with increase in temperature.

### 3.1.6 Specific Weight

Specific weight of a fluid,  $\gamma$

- Definition: weight of the fluid per unit volume
- Arising from the existence of a gravitational force
- The relationship  $\gamma$  and  $\rho$  can be found using the following:

Since  $\rho = \frac{m}{v}$

therefore  $\gamma = \rho g$

- **Units:**  $\text{N}/\text{m}^3$
- **Typical values:**

Water =  $9814 \text{ N}/\text{m}^3$ ;

Air =  $12.07 \text{ N}/\text{m}^3$

### 3.1.7 Specific Gravity

The specific gravity (or relative density) can be defined in two ways:

Definition 1: A ratio of the density of a liquid to the density of water at standard temperature and pressure (STP) ( $20^\circ\text{C}$ , 1 atm), or

Definition 2: A ratio of the specific weight of a liquid to the specific weight of water at standard temperature and pressure (STP) ( $20^\circ\text{C}$ , 1 atm),



$$\left[ \frac{\rho_{\text{liquid}}}{\rho_{\text{water@STP}}} = \frac{\gamma_{\text{liquid}}}{\gamma_{\text{water@STP}}} \right]$$

- **Unit:** dimensionless.

### 3.1.8 Surface Tension

- Surface tension coefficient  $s$  can be defined as the intensity of intermolecular traction per unit length along the free surface of a fluid, and its SI unit is N/m.
- The surface tension effect is caused by unbalanced cohesion forces at fluid surfaces which produce a downward resultant force which can physically be seen as a membrane.
- The coefficient is inversely proportional to temperature and is also dependent on the type of the solid interface.
- For example, a drop of water on a glass surface will have a different coefficient from the similar amount of water on a wood surface.
- The effect may be becoming significant for small fluid system such as liquid level in a capillary, as depicted in following figure, where it will decide whether the interaction form by the fluid and the solid surface is wetted or non-wetted.

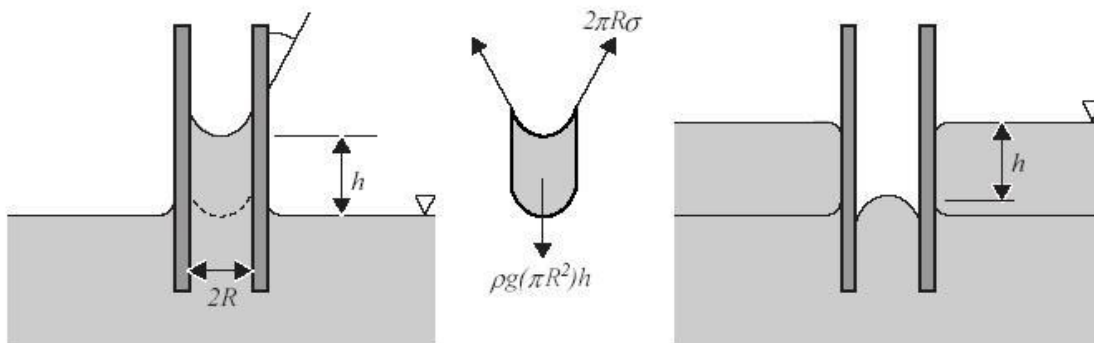
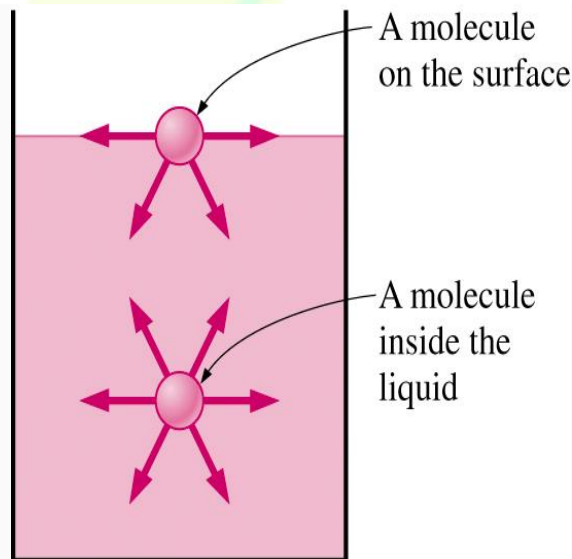

**Figure 1.6:** Capillary Actions for Wetted and Non-Wetted Surfaces

## Fluids Mechanics

- If the adhesion of fluid molecules to the adjacent solid surface is stronger than the intermolecular cohesion, the fluid is said to *wet* on the surface. Otherwise, it is a non-wetted interaction.
- The pressure inside a drop of fluid can be calculated using a free-body diagram of a spherical shape of radius  $R$  cut in half, as shown in following figure, and the force developed around the edge of the cut sphere is  $2pR$ .

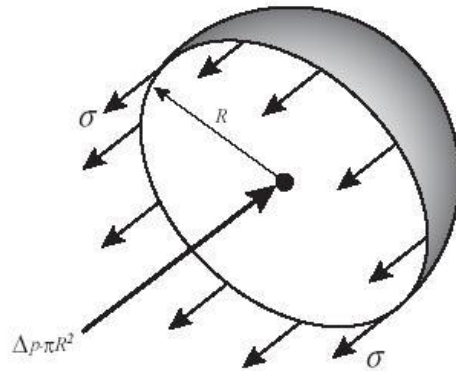

Figure 1.7: Force acting on one-half of a liquid drop

- This force must be balance with the difference between the internal pressure  $p_i$  and the external pressure  $p_e$  acting on the circular area of the cut. Thus,

$$2R\sigma = \Delta p \pi R^2$$

$$\Delta p = \frac{2\sigma}{R}$$

### 3.1.9 Vapour Pressure and cavitation

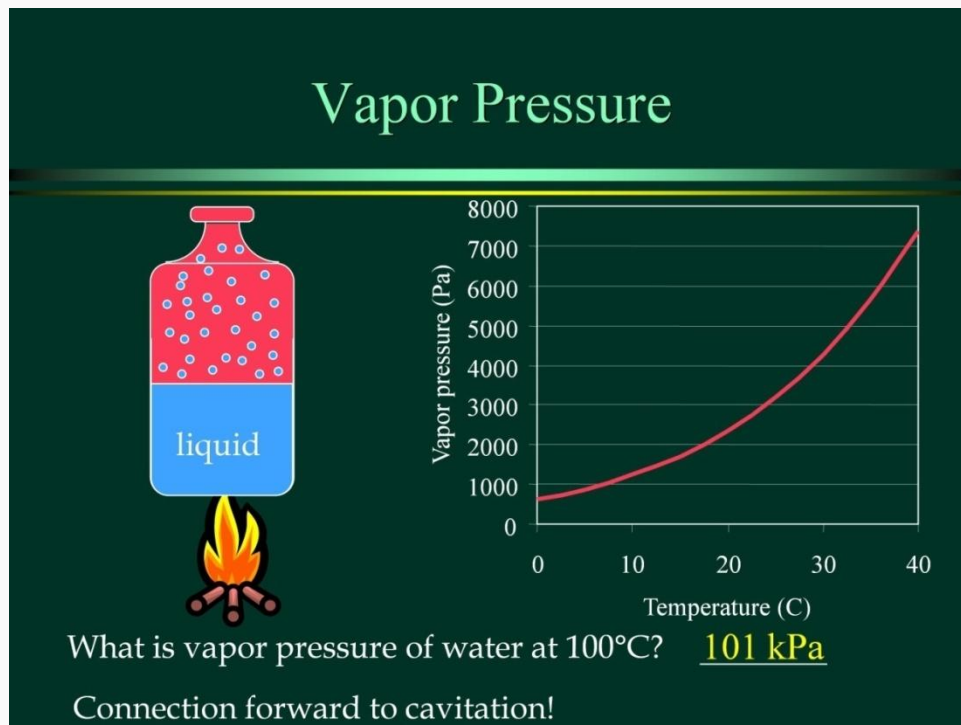

Vapour pressure is the partial pressure produced by fluid vapour in an open or a closed container, which reaches its saturated condition or the transfer of fluid molecules is at equilibrium along its free surface.

## Fluids Mechanics

In a closed container, the vapour pressure is solely dependent on temperature. In a saturated condition, any further reduction in temperature or atmospheric pressure below its dew point will lead to the formation of water droplets.

On the other hand, boiling occurs when the absolute fluid pressure is reduced until it is lower than the vapour pressure of the fluid at that temperature.

For a network of pipes, the pressure at a point can be lower than the vapour pressure, for example, at the suction section of a pump. Otherwise, vapour bubbles will start to form and this phenomenon is termed as cavitation.

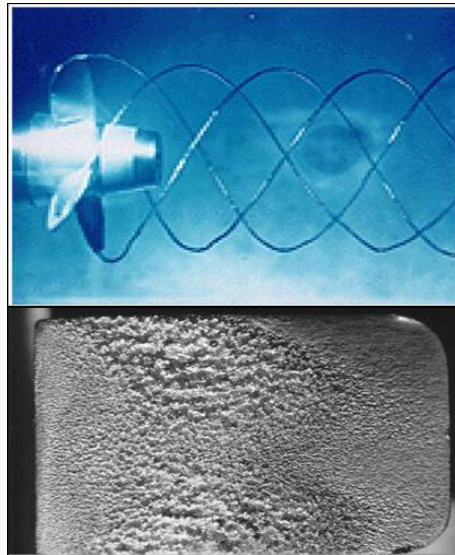

In short:

- **Vapor Pressure**  $P_v$  is defined as the pressure exerted by its vapor in phase equilibrium with its liquid at a given temperature
- If  $P$  drops below  $P_v$ , liquid is locally vaporized, creating cavities of vapor.
- Vapor cavities collapse when local  $P$  rises above  $P_v$ .
- Collapse of cavities is a violent process which can damage machinery.

Cavitation is noisy, and can cause structural vibrations

### 3.2 REAL and ideal fluids

- (1) Ideal fluid – no friction, fluid can ‘slide’ tangentially along the solid boundary.
- (2) Real fluid – will possess friction (or viscosity), fluid cannot ‘slide’ along boundary – no slip boundary condition. Tangential velocity = zero if the wall is at rest.
- (3) Velocity component perpendicular to the wall must be the same as that of the wall – no penetration condition (= zero if the wall is at rest).

An ideal fluid is assumed

- to be incompressible (so that its density does not change),
- to flow at a steady rate,

## Fluids Mechanics

- to be nonviscous (no friction between the fluid and the container through which it is flowing), and
- flows irrotationally (no swirls or eddies).
- In a real fluid viscosity produces resistance to motion by causing shear or friction forces between fluid particles and between these and boundary walls.
- Due to this viscous effects, fluid tends to 'stick' to solid surfaces and have stresses within their body.
- The inclusion of viscosity allows the existence of two physically distinct flow regimes, known as laminar and turbulent flow.



MODULE 3. PRESSURE AND ITS MEASUREMENT

LESSON 4. PRESSURE

4.1 WHAT IS PRESSURE?

- Pressure is the average of the normal forces acting at a point
- Differences between normal forces are due to fluid motion

In this case, if the force vectors are equal in magnitude, then

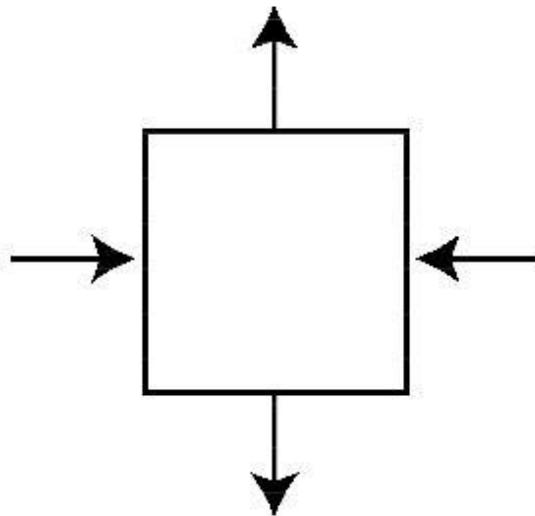

$p = 0$

- The basic property of a static fluid is pressure.
- Pressure is defined as the amount of surface force exerted by a fluid on any boundary it is in contact with. It can be written as:

$$[Pressure = \frac{Force}{Area} \text{ of which the force is applied}]$$
$$[P = \frac{F}{A} \quad ]$$

Unit: N / m<sup>2</sup> or Pascal (Pa).

(Also frequently used is bar, where 1 bar = 10<sup>5</sup> Pa).

4.2 Absolute Pressure, Gage Pressure, and Vacuum

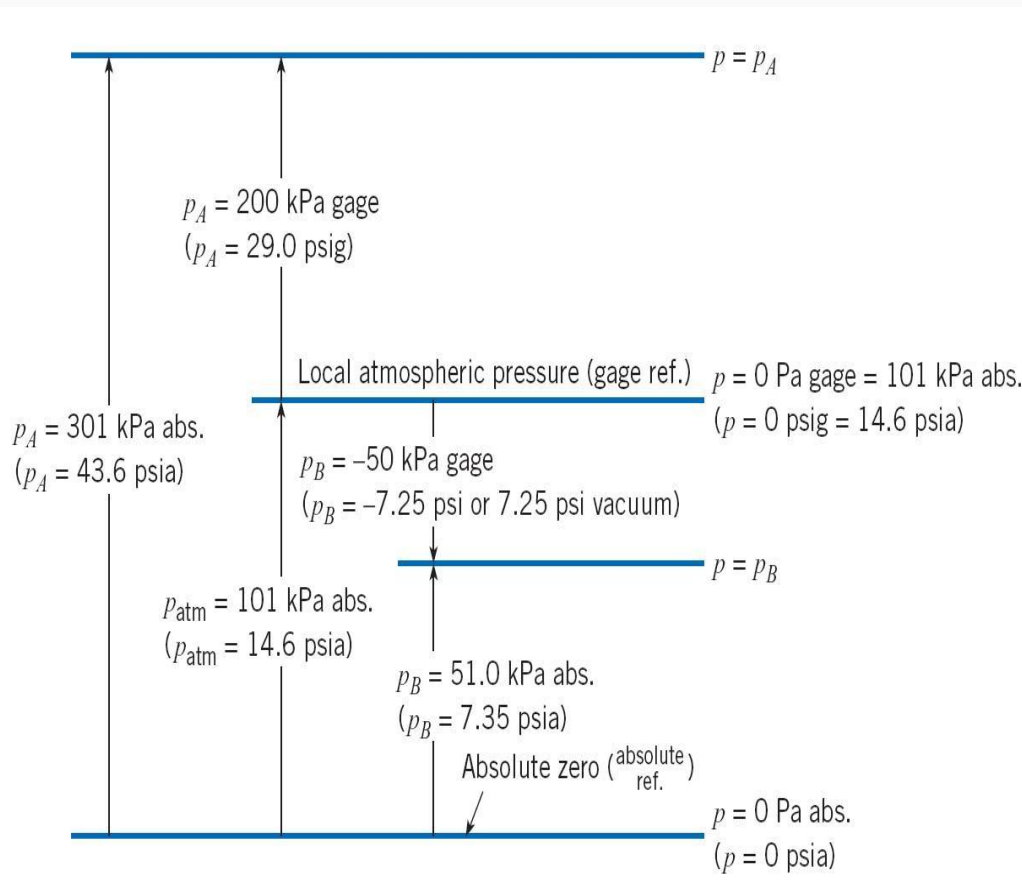

- Pressure in a vacuum is  $p = 0$ .
- Absolute pressure is referenced to perfect vacuum.
- Gage pressure is referenced to another pressure, typically atmospheric pressure (most gages measure relative pressures).
- Pressure measurements are generally indicated as being either absolute or gage pressure.
- is the pressure measured above or below the atmospheric pressure (i.e. taking the atmospheric as datum).
- can be positive or negative.
- A negative gage pressure is also known as vacuum pressure.
- uses absolute zero, which is the lowest possible pressure.
- Therefore, an absolute pressure will always be positive.
- refers to the prevailing pressure in the air around us.
- It varies somewhat with changing weather conditions, and it decreases with increasing altitude.

## Fluids Mechanics

- At sea level, average atmospheric pressure is 101.3 kPa (abs), 14.7 psi (abs), or 1 atmosphere (1 bar =  $1 \times 10^5$  Pa).
- This is commonly referred to as 'standard atmospheric pressure'.
- A simple equation relating the two pressure measuring system can be written as

### 4.2.1 Gauge pressure

- is the pressure measured above or below the atmospheric pressure (i.e. taking the atmospheric as datum).
- can be positive or negative.
- A negative gauge pressure is also known as vacuum pressure.

### 4.2.2 Absolute pressure

- uses absolute zero, which is the lowest possible pressure.
- Therefore, an absolute pressure will always be positive.

### 4.2.3 Atmospheric pressure

- refers to the prevailing pressure in the air around us.
- It varies somewhat with changing weather conditions, and it decreases with increasing altitude.
- At sea level, average atmospheric pressure is 101.3 kPa (abs), 14.7 psi (abs), or 1 atmosphere (1 bar =  $1 \times 10^5$  Pa).
- This is commonly referred to as 'standard atmospheric pressure'.
- A simple equation relating the two pressure measuring system can be written as:

$$P_{\text{abs}} = P_{\text{gauge}} + P_{\text{atm}}$$

- Pressure acts uniformly in all directions on a small volume of fluid.
- In a fluid confined by solid boundaries, pressure acts perpendicular to the boundary.
- These principles, called **Pascal's Law**,

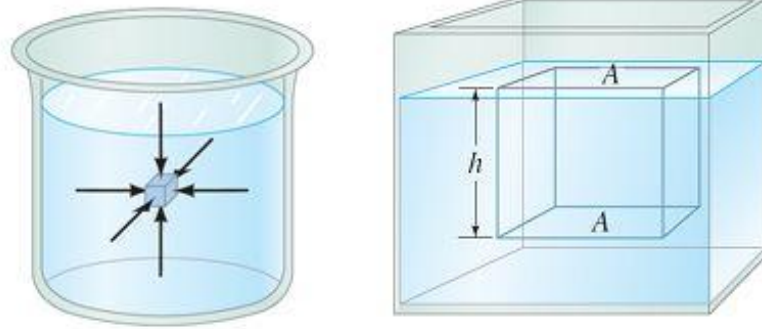

The pressure is the same in every direction in a fluid at a given depth.

Pressure varies with depth

Fluid surfaces

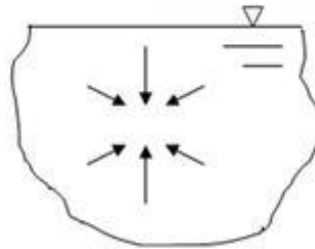

Figure 4.1 ; Pressure acts uniformly

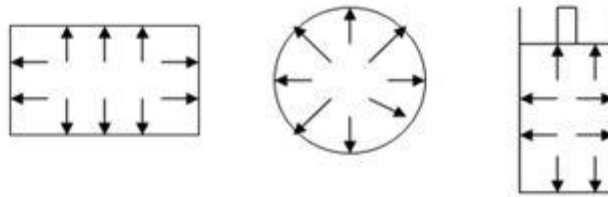
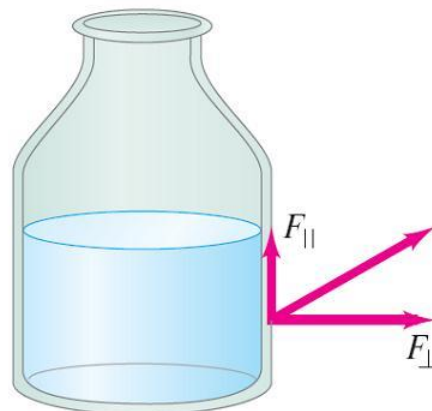

Figure 4.2 ; Directions of fluid pressure on boundary

- A fluid at rest exerts pressure perpendicular to any surface that it contacts. There is no parallel component that would cause a fluid at rest to flow.





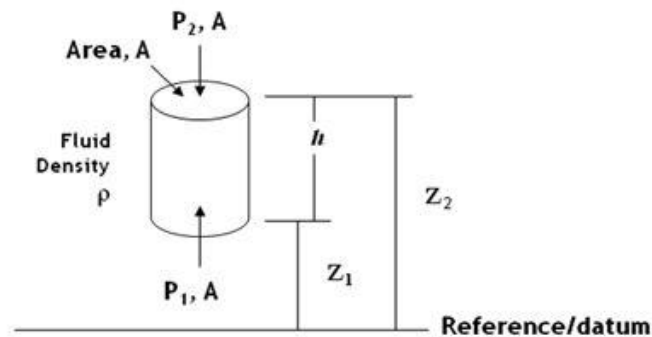
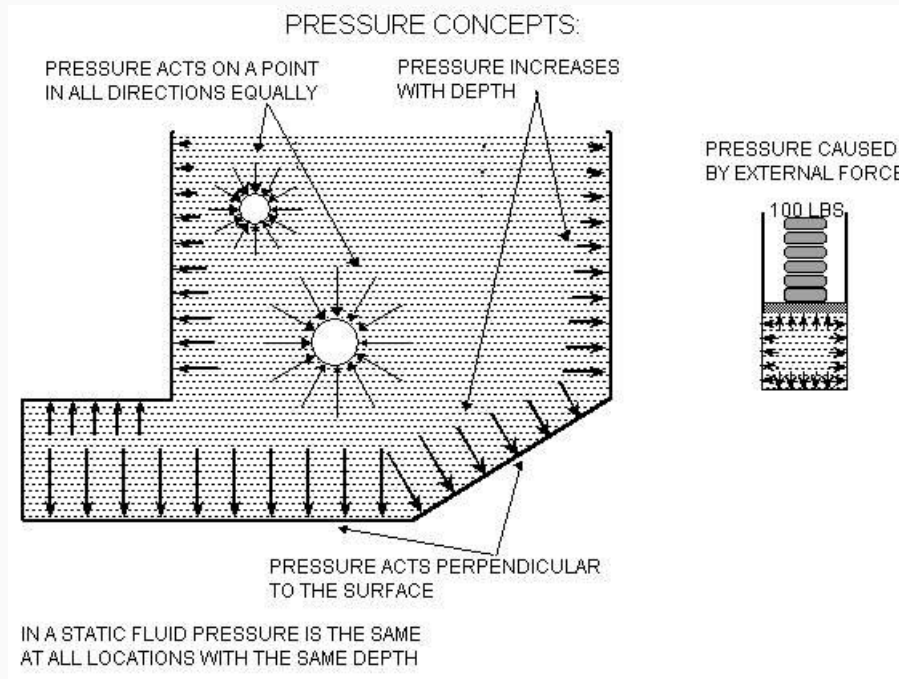

Figure: Small cylindrical element of fluid

### 4.3 Variations of Pressure with Elevation

- To find the variations of pressure with elevation, let's consider a small cylindrical element of fluid of cross-sectional area  $A$ , and height ( $h = Z_2 - Z_1$ ), surrounded by the same fluid of mass density,  $\rho$ .
- The pressure at the bottom of the cylinder is  $P_1$  at level  $Z_1$ , and at the top is  $P_2$  at level  $Z_2$ . The fluid is at rest and in equilibrium so all the forces in the vertical direction sum to zero.
  - Force due to  $P_1$  (upward) =  $P_1A$
  - Force due to  $P_2$  (downward) =  $P_2A$
  - Force due to weight of element =  $mg = \rho gA(Z_2 - Z_1)$
  - Taking the summation of forces (upward as positive);

## Fluids Mechanics

$$(\uparrow)\Sigma F=0$$

$$P_1A - P_2A - \rho gA(Z_2-Z_1) = 0$$

$$P_1 - P_2 = \rho g (Z_2-Z_1) = \rho gh$$

$$\text{or } P_2 - P_1 = - \rho g(Z_2-Z_1) = - \rho gh$$

Thus, in any fluid under gravity,

- an increase in elevation causes a decrease in pressure.
- a decrease in elevation causes an increase in pres



AGRIMOON.COM  
All About Agriculture...

## LESSON 5. PRESSURE MEASUREMENT

### 5.1 Atmospheric pressure

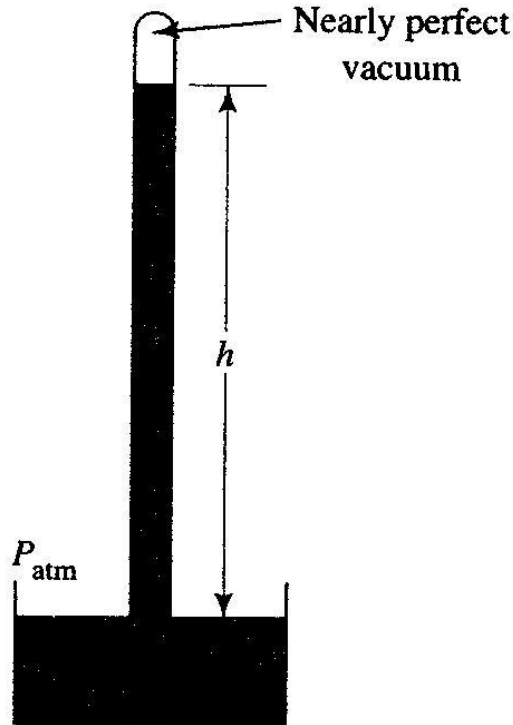

- Atmospheric pressure is usually measured by a mercury barometer.
- A simple barometer consists of a tube more than 760 mm (30 inch) long inserted in an open container of mercury with a closed and evacuated end at the top and open end at the bottom with mercury extending from the container up into the tube.
- A void is produced at the top of the tube which is very nearly a perfect vacuum. Figure 2.10 below shows an example of a barometer.
- Mercury rises in the tube to a height of approximately 760 mm (30 in.) at sea level.
- The level of mercury will rise and fall as atmospheric pressure changes; direct reading of the mercury level gives prevailing atmospheric pressure as a pressure head (of mercury), which can be converted to pressure using the relation:

$$P_{\text{atm}} = \rho gh.$$

### 5.2 Piezometer tube

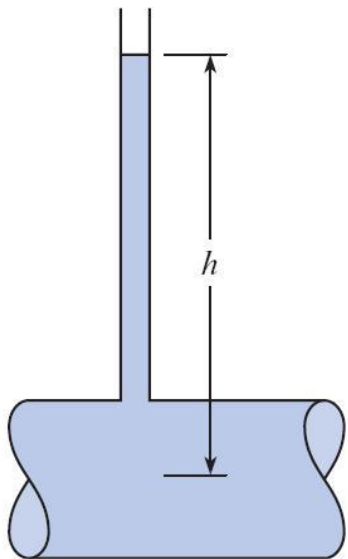

$$P = \gamma h$$

- A simple vertical tube open at the top, which is attached to the system containing the liquid where the pressure (higher than atmospheric pressure) to be measured.
- As the tube is open to the atmosphere, the pressure measured is the gauge pressure.
- When Piezometric is used to measure the pressure it is called as monometers.
- Monometers are classified as:
  - Simple
  - Differential
  - Micro monometers

### 5.3 U-tube manometer

- One end of the U-tube is connected to the pressure that is to be measured, while the other end is left open to atmosphere.
- The tube contains a liquid, which is called the manometric fluid, which does not mix with the fluid whose pressure is to be measured.
- The fluid whose pressure is being measured should have a lesser density than the manometric fluid. ( $\rho < \rho_{\text{man}}$ )
- Better for higher pressures.
- Possible to measure pressure in gases.
- Possible to measure pressure in gases.

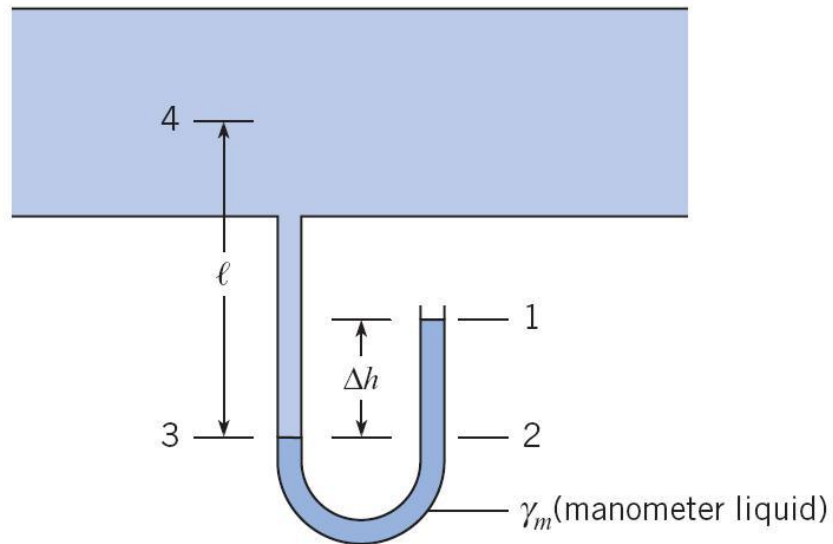

- Pressure change from 1 to 2 is  $\gamma_m \Delta h$
- Pressure change from 3 to 4 is  $\gamma l$
- Pressure in pipe is  $P_p$

$$0 + \gamma_m \Delta h - \gamma l = P_p$$

### 5.4 Differential Manometer

- In some cases, the difference between the pressures at two different points is desired rather than the actual value of the pressure at each point.
- A manometer to determine this pressure difference is called the differential manometer (see figure below).
- The liquids in manometer will rise or fall as the pressure at either end (or both ends) of the tube changes.

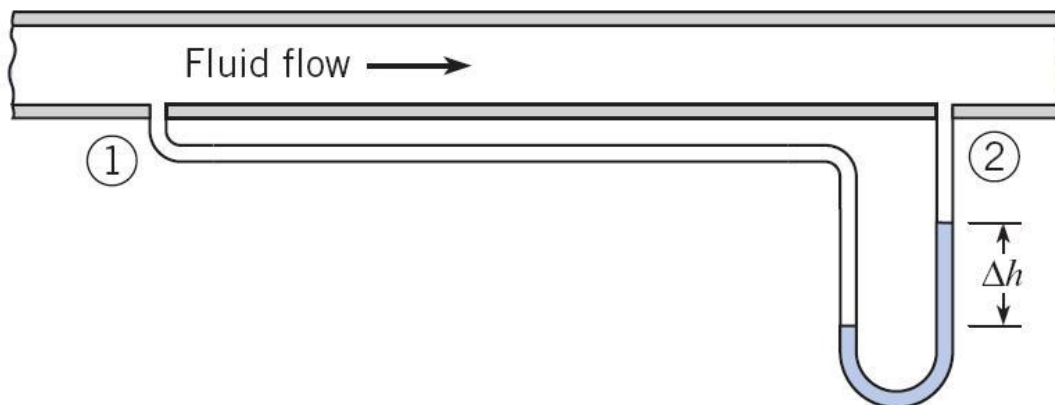

5.5 Pressure Gauges

- The pressure to be measured is applied to a curved tube, oval in cross section.
- Pressure applied to the tube tends to cause the tube to straighten out, and the deflection of the end of the tube is communicated through a system of levers to a recording needle.
- This gauge is widely used for steam and compressed gases.
- The pressure indicated is the difference between that communicated by the system to the external (ambient) pressure, and is usually referred to as the gauge pressure.

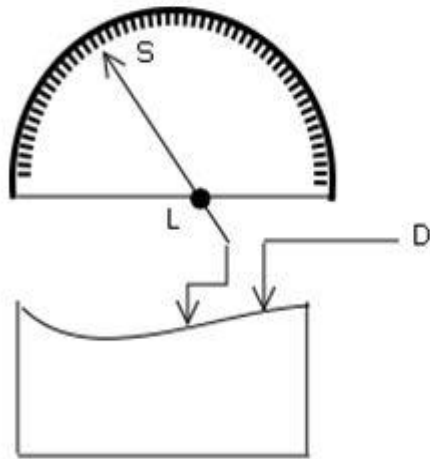

Aneroid

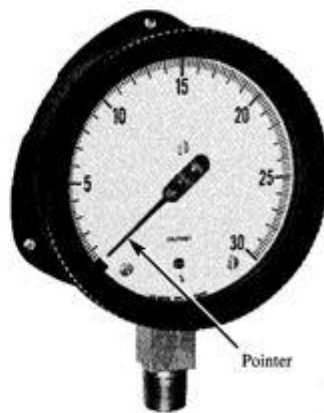
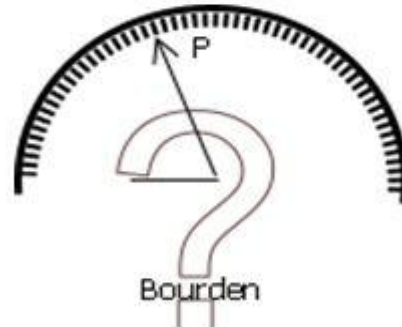

(a) Front view

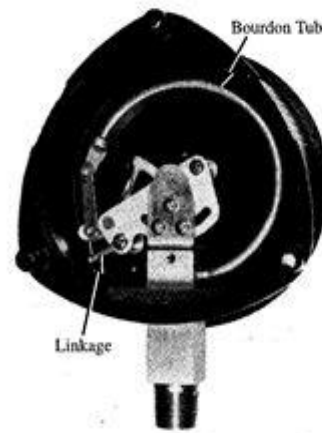

(b) Rear view with back of case removed



MODULE 4. PASCAL'S LAW

LESSON 6. PASCAL'S LAW

Pascal's Principle

if an external pressure is applied to a confined fluid, the pressure at every point within the fluid increases by that amount. Applications: hydraulic lift and brakes

$$P_{out} = P_{in}$$

And since  $P = F/a$

$$\frac{F_{out}}{A_{out}} = \frac{F_{in}}{A_{in}}$$

Mechanical Advantage:

$$\frac{F_{out}}{F_{in}} = \frac{A_{out}}{A_{in}}$$

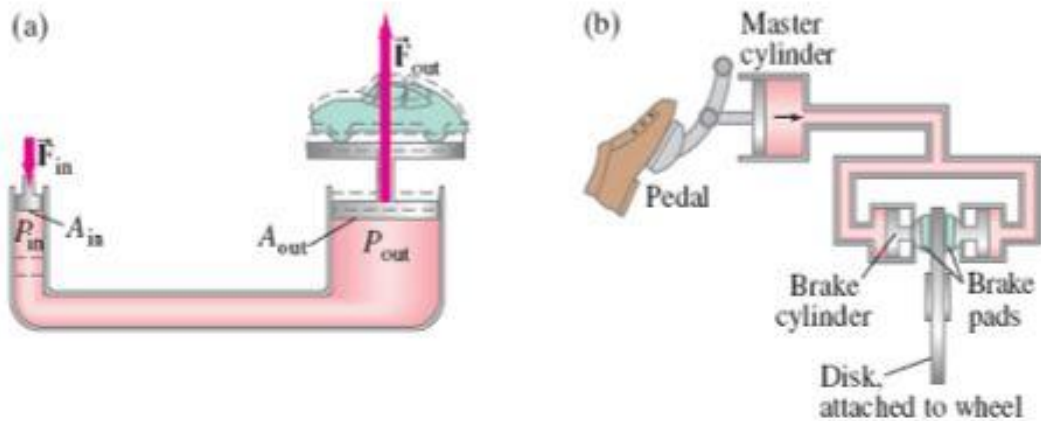

Pascal's law

- Pressure acts uniformly in all directions on a small volume of fluid.
- In a fluid confined by solid boundaries, pressure acts perpendicular to the boundary.
- These principles, called **Pascal's Law**,

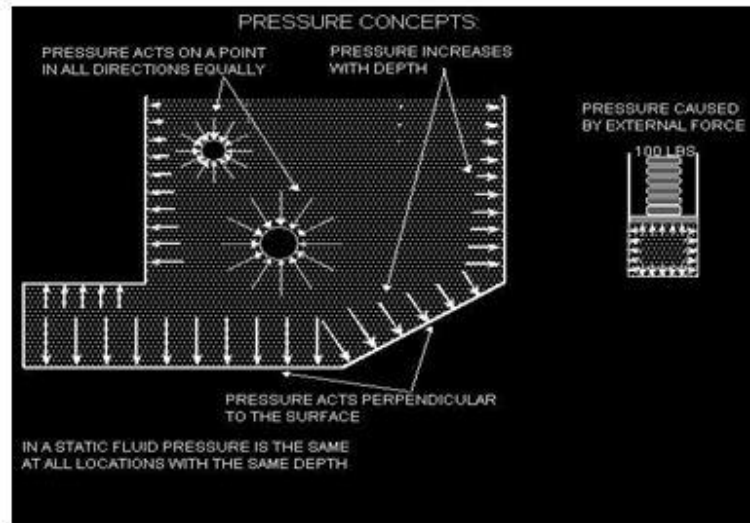
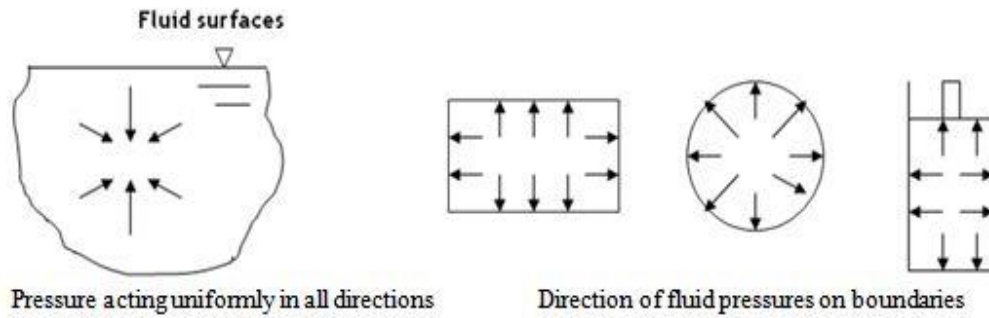

### Application of Pascal’s law

#### 1. A Hydraulic Jack Lifting a Car

The back end (half the weight) of a car of mass 2000 kg is lifted by an hydraulic jack where the  $A_s/A_l$  ratio is 0.1 (the area of the large cylinder is 10 times the area of the small cylinder).

The force (weight) acting on the large cylinder can be calculated with Newton's Second Law:

$$F_1 = m a$$

where

$m$  = mass (kg)

$a$  = acceleration of gravity ( $m/s^2$ )

or

$$F_1 = 1/2 \ 2000 \ (kg) \ 9.81 \ (m/s^2)$$

$$= 9810 \ (N)$$



## Fluids Mechanics

The force acting on the small cylinder can be calculated with (2d)

$$F_s = 9810 \text{ (N)} \cdot 0.1$$

$$= \underline{981} \text{ (N)}$$

2. The siphon

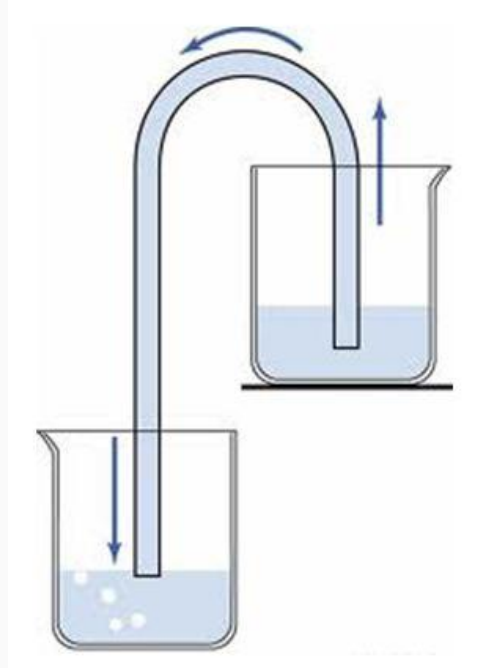

A siphon works because gravity pulling down on the taller column of liquid causes reduced pressure at the top of the siphon

3. The underlying principle of the hydraulic jack and hydraulic press

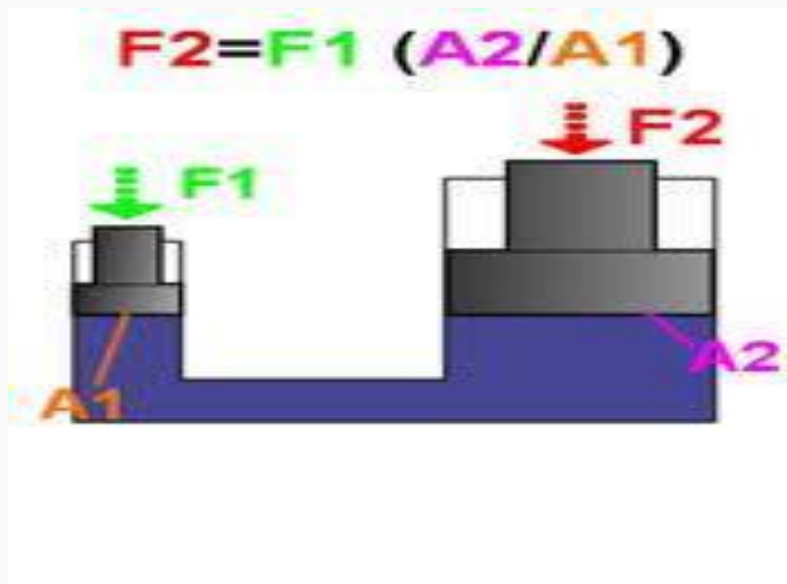

4. Force amplification in the braking system of most motor vehicles.

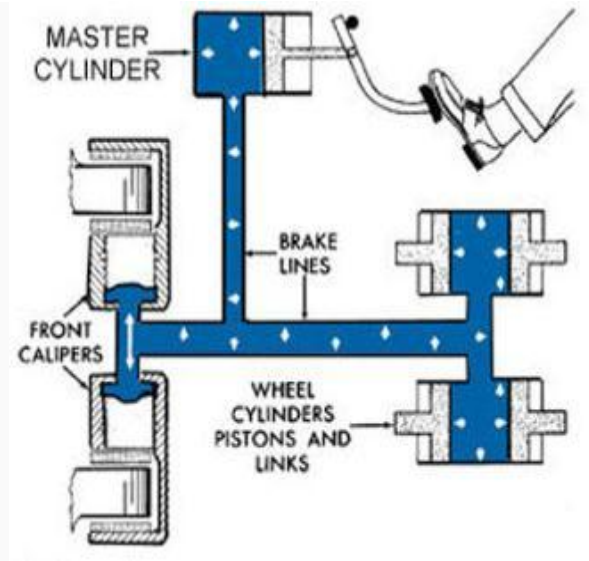

5. Used in artesian wells, water towers, and dams.

6. At a depth of 10 meters under water, pressure is twice the atmospheric pressure at sea level, and increases by about 100 kPa for each increase of 10 m depth.

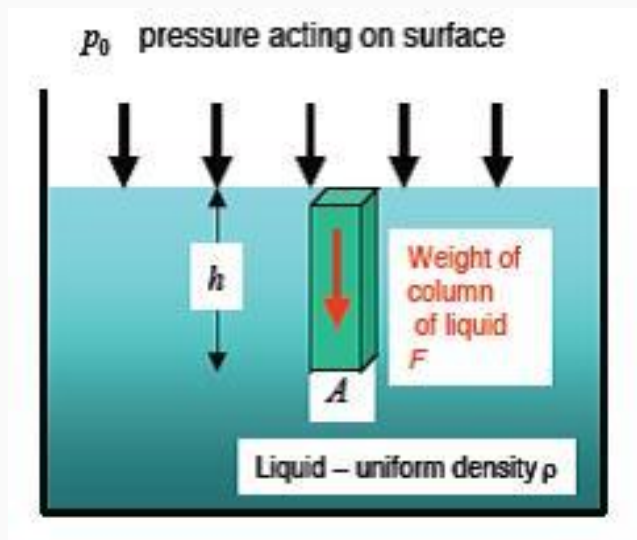

In a static fluid, with uniform density  $\rho$ ,

Pressure at depth,  $h$  = pressure acting on surface + pressure due to height of liquid

$$P_h = P_0 + F/A$$

$F$  = weight of column liquid of cross sectional area  $A$

$$F = mg$$

$$M = \rho V = \rho Ah$$

$$F/A = \rho gh$$

$$P_h = P_0 + \rho gh$$

MODULE 5. PRESSURE FORCES ON PLANE AND CURVED SURFACES

LESSON 7. PRESSURE FORCES ON PLANE SURFACES

Hydrostatic Forces on Plane Surfaces

- Pressure has been defined as force divided by the area on which it acts. This principle can be restated as when a fluid is adjacent to a fixed surface, it exerts a force on the surface because of the pressure in the liquid. For fluid at rest, the force always acts at right angles to the surface

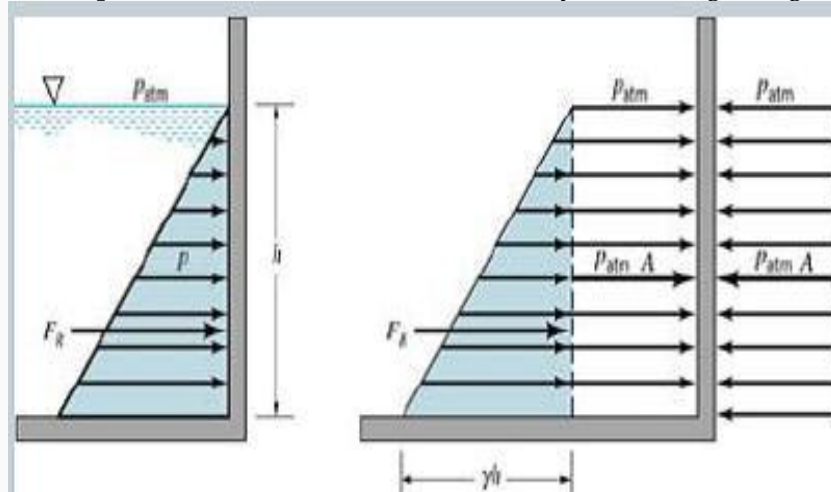

- For horizontal plane submerged in a liquid, the pressure,  $P$ , will be equal at all points of the surface. This leads to the conclusion that the resultant force on horizontal surface due to that pressure can be computed from the simple product of pressure times the area of interest, i.e.

Force = Pressure x Area of plane

$$F = PA$$

This force will act vertically downward and through the center of pressure

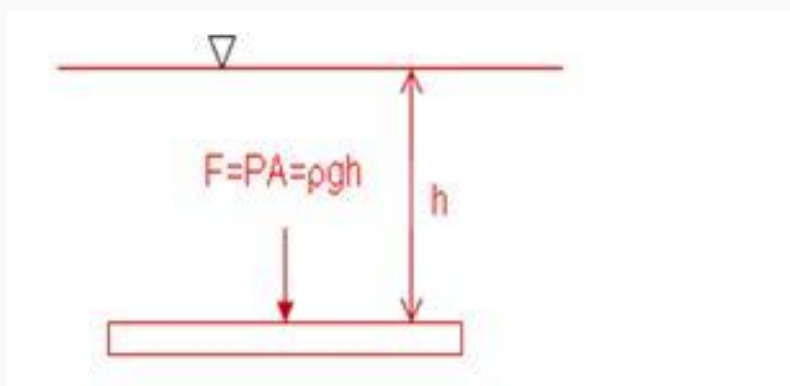

Resultant force on horizontal plane



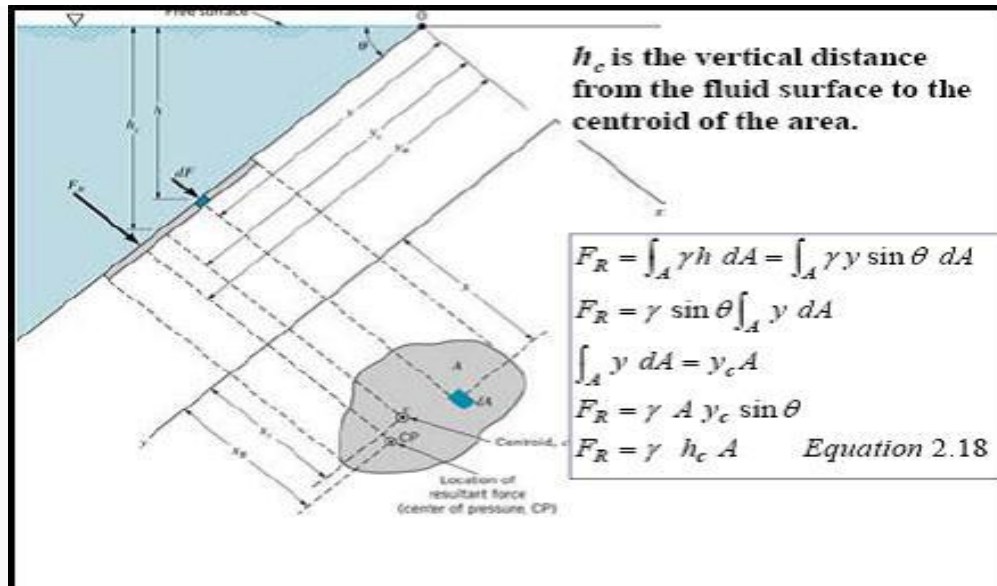

**Resultant Force and Center of Pressure on a Submerged Plane Surface in a Liquid**

- below shows a plane surface PQ of an area A submerged in a liquid of density,  $\rho$ , and inclined at an angle  $\theta$  to the free surface.
- Considering one side only, there will be a force due to fluid pressure, acting on each element of area  $dA$ , the magnitude of the pressure will depend on the vertical depth  $y$  of the element below the free surface. Taking the pressure at the free surface as zero, the pressure at a distance  $y$  below the free surface can be written as:

$$p = \rho g y.$$

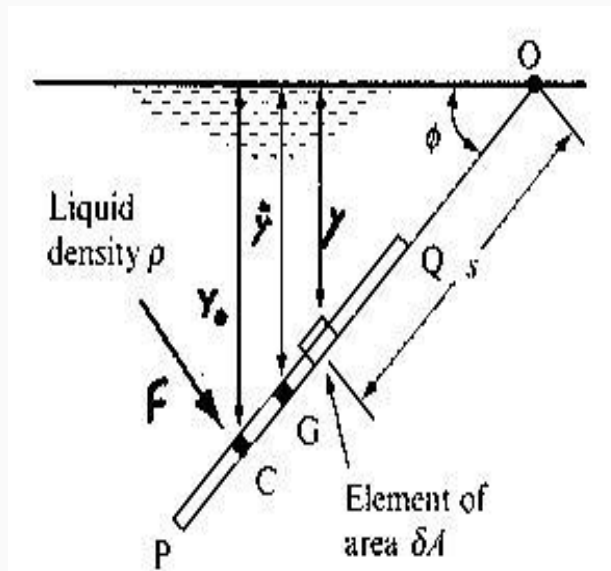

Figure 1. Resultant force on a plane surface immersed in a fluid

- Force on elemental area  $\delta A$ :

$$dF = P\delta A = \rho g y \delta A \quad (1)$$

## Fluids Mechanics

- The resultant force acting on the plane can be found by summing all the forces on the small element:

$$F = \Sigma P \delta A = \Sigma \rho g y \delta A \quad (2)$$

- Assuming that  $r$  and  $g$  are constant,

$$F = \rho g \Sigma y \delta A \quad (3)$$

- The quantity  $\Sigma y \delta A$  is the first moment of area under the surface PQ about the free surface of the liquid and is equal to  $A \hat{y}$ , where  $A$  = the area of the whole immersed surface and  $\hat{y}$  = vertical distance from the free surface to the centroid of the area,  $G$ , of the immersed surface.
- Centroid of the area is defined as the point at which the area would be balanced if suspended from that point. It is equivalent to the center of gravity of a solid body.
- Substituting into equation (2) will give

$$F = \rho g \hat{y} A \quad (4)$$

- It may be noted that the resultant force,  $F$ , is independent of the angle of inclination  $\theta$  so long as the depth of the centroid  $\hat{y}$  is unchanged.
- The point of application of the resultant force on the submerged area is called the center of pressure. This resultant force will act perpendicular to the immersed surface at the center of pressure,  $C$ .
- The vertical depth of the center of pressure,  $y_0$ , below the free surface can be found using the following:

$$y_0 = \hat{y} + \frac{I_G}{A \hat{y}} \quad \dots(5)$$

- where

$I_G$  = second moment of plane area about its center of gravity

$A$  = the area of the whole immersed surface

$\hat{y}$  = vertical distance from the free surface to the centroid of the area  $A$

- The above equation implies that the center of pressure is always below the centroid.



### MODULE 6. BUOYANCY, METACENTRE AND METACENTRIC HEIGHT, CONDITION OF FLOATATION AND STABILITY OF SUBMERGED AND FLOATING BODIES

#### LESSON 8. BUOYANCY

A Greek scientist named Archimedes discovered an important scientific law related to buoyancy.

It can be expressed as:

‘Any object, wholly or partially immersed in a fluid, is buoyed up by a force equal to the weight of the fluid displaced by the object.’

It is used by architects and engineers when they design ships, submarines and various other floating structures.

1. The buoyant force exerted on a submerged or floating body is equal to the weight of the fluid displaced by the body.
2. A floating body displaces a weight of fluid equal to its own weight; i.e., a floating body is in equilibrium.

The center of buoyancy is located at the centroid of the displaced fluid volume.

In the case of a body lying at the interface of two immiscible fluids, the buoyant force equals the sum of the weights of the fluids displaced by the body.

- When a body is submerged or floating in a static fluid, the resultant force exerted on it by the fluid is called the buoyancy force. This buoyancy force is always acting vertically upward, and has the following characteristics;
- The buoyancy force is equal to the weight of the fluid displaced by the solid body.
- The buoyancy force acts through the centroid of the displaced volume of fluid, called the center of buoyancy.
- A floating body displaces a volume of fluid whose weight is equal to the weight of the body
- The above principle is known Archimedes’ principle and can be defined mathematically as demonstrated below ;
- The buoyancy of a body wholly or partly immersed in a fluid at rest , situated in a gravitational field or other field of force is defined as the upward thrust of the fluid on the body. Generally all problems relating to buoyancy can be resolved by applying the **principles of Archimedes.**

In short

**“The buoyancy of any body is vectorially equal and opposite to the weight of the fluid displaced by the body and has the same line of action”.**

## Fluids Mechanics

- The upward thrust which the surrounding fluid exerts on an object is referred to as the force of buoyancy.
- This thrust acts through the centroid of the displaced volume, referred to as the centre of buoyancy.
- The centre of buoyancy is not the same as the centre of gravity which relates to the distribution of weight within the object.
- If the object is a solid with a uniform density exactly the same as water and the body is immersed in water the force of buoyancy will be exactly equal to the weight and the centre of buoyancy will be the same as the centre of gravity.
- The object will be in equilibrium with the surrounding fluid.
- This principle also applied to gases as well as liquids and explains why balloons filled with gases which have lower density compared to air rise to such a height that the weight of the air displaced is equal to the weight of the gas in the balloon.
- A body which hovers in a fluid and is in equilibrium is said to have neutral buoyancy.

If the centre of gravity (G) is not in the same location as the centroid (centre of buoyancy-B). The body will orient itself such that the centre of Gravity is below the centre of buoyancy. (See diagram below). The diagram below shows a hollow vessel with a heavy weight occupying a small segment. The diagram below shows the object in a fully stable equilibrium position. In theory if the G was vertically above B then there is no force (moment) tending to rotate the object and it is still in a position of equilibrium. In this position however it is considered to be unstable.

### Metacentre and Metacentric Height

Consider a rectangular vessel immersed as shown below in the first figure the centre of buoyancy at B and the centre of gravity is at G. with the water line at S-S Now if the vessel is heeled such that the water line is at S'=S'. The centre of buoyancy now moves to B' as shown in the second figure below. There is now an upthrust (W) due to buoyancy at B' and the weight of the vessel (W) is acting down at G and there is a couple  $W \cdot a$  acting to restore the vessel to its original position. The locus of each position of B' as the vessel heels to different angles is called the buoyancy curve. Also the curve joining the tangents of each line of thrust, drawn relative to the vessel, is known as the curve of metacentres. The cusp of this curve is known as the initial metacentre. This is shown on the third figure which combines the first and second figures

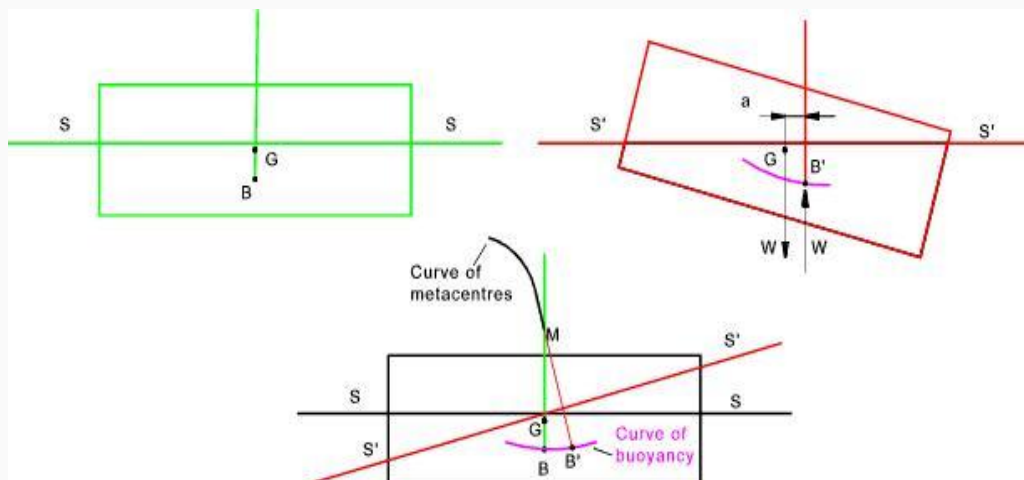



## Fluids Mechanics

The initial metacentre M is the point where the line of action of the upthrust intersects the original vertical line through the centre of buoyancy B and the centre of gravity G for an infinitesimal angle of heel.

The righting moment is calculated as  $W.GM.\sin\theta$ . The angle of heel being  $\theta$ . For small values of heel up to about  $15^\circ$  GM is fairly constant and is the value generally accepted as the transverse metacentric height of the vessel

**A floating vessel is stable if the metacentre lies above the centre of gravity G.**

**A floating vessel is in neutral equilibrium if the metacentre lies on the centre of gravity G.**

**A floating vessel is unstable if the metacentre lies below the centre of gravity G.**

### Centre of Pressure on Submerged surfaces

The point at which the resultant fluid force is considered to act on a plane area is called its **centre of pressure**. This is shown on the above figure at point P. This point is found by summing the moments of the elementary forces about the imaginary axis. O - O'.

$$M = \sum \delta M = \sum p \times \delta A = \rho g \sin \theta \sum x^2 \delta A$$

This is equivalent to the moment exerted by the resultant force F acting through the centre of pressure P. Thus

$$M = F x_P = [\rho g \sin \theta \sum x \delta A] x_P$$

And from above the force (F) on the plate is

$$F = \rho g \sin \theta \sum x \delta A$$

Therefore,

$$x_P = \frac{\sum x^2 \delta A}{\sum x \delta A} = \frac{\text{Second Moment of Area about O-O'}}{\text{First Moment of Area about O-O'}}$$

The second moment of area of the plane figure about its centroid G is  $I_G$

The first moment of area of a plane figure about O-O =  $A.x_G$ .

Using the parallel axis theorem  $I_O = I_G + A.x_G^2$ .

This can be expressed in terms of radii of gyration as  $A.k_O^2 = A[k_G^2 + x_G^2]$  Therefore

$$x_P = \frac{I_O}{A.x_G} = \frac{A.k_O^2}{A.x_G} = \frac{k_G^2 + x_G^2}{x_G} = \frac{k_G^2}{x_G} + x_G$$

Therefore the centre of pressure of a plane area lies below the centroid G of the area by a distance  $P - G = x_P - x_G = k_G^2 / x_G$  measured along the slope of the plane. As the radius of gyration of the surface about its centroid  $k_G$  is fixed the difference reduces as the depth of the surface increases.

### Theory

Floating bodies are a special case; only a portion of the body is submerged, with the remainder poking of the free surface. The buoyancy,  $F_b$ , which is the weight of the displaced water, i.e.,

## Fluids Mechanics

submerged body portion, is equal to its dead weight,  $F_G$ . The centre of gravity of the displaced water mass is referred to as the centre of buoyancy,  $A$  and the centre of gravity of the body is known as the centre of mass,  $S$ .

In Equilibrium position buoyancy force,  $F_A$ , and dead weight,  $F_G$ , have the same line of action and are equal and opposite (see Fig. 2). A submerged body is stable if its center of mass locates below the center of buoyancy. However, this is not the essential condition for stability in floating objects

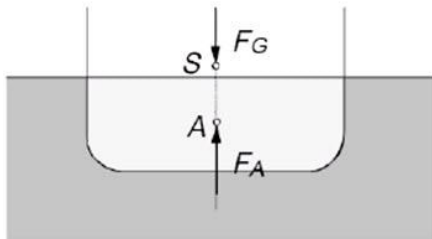

Figure 2- Buoyancy force and center of buoyancy

A floating object is stable as far as a resetting moment exists in the event of deflection or tilting from the equilibrium position. As shown in Fig. 3, dead weight  $F_G$  and buoyancy  $F_A$  form a force couple with the lever arm of  $B$ , which provides a righting moment. The distance between the centre of gravity and the point of intersection of line of action of buoyancy and symmetry axis, is a measure of stability. The point of intersection is referred to as the metacenter,  $M$ , and the distance between the centre of gravity and the metacenter is called the metacentric height  $Z_M$ .

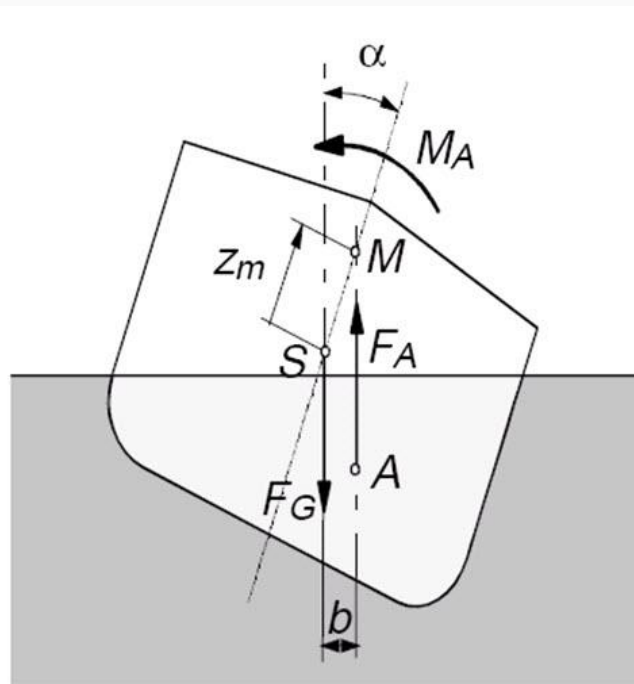

Figure 3- Metacenter and metacentric height

The floating object is stable when the metacentric height  $Z_m$  is positive, i.e., the metacenter is located above the centre of gravity; else it is unstable.

## Fluids Mechanics

The position of the metacenter is not governed by the position of the centre of gravity. It merely depends on the shape of the portion of the body under water. There are two methods of determining the metacenter position.

In the first method, the centre of gravity is laterally shifted by a certain constant distance,  $X_s$ , using an additional weight, causing the body to tilt. Further vertical shifting of the centre of gravity alters the heel angle  $\alpha$ . A stability gradient formed from the derivation  $dx_s/da$  is then defined which decreases as the vertical centre of gravity position approaches the metacentre. If centre of gravity position and metacentre coincide, the stability gradient is equal to zero and the system is stable. This problem is easily solved graphically (see Fig. 4). The vertical centre of gravity position is plotted versus the stability gradient. A curve is drawn through the measured points and extrapolated as far as it contacts the vertical axis. The point of intersection with the vertical axis locates the position of the metacentre.

The metacentric height can also be evaluated theoretically using the following relationship:

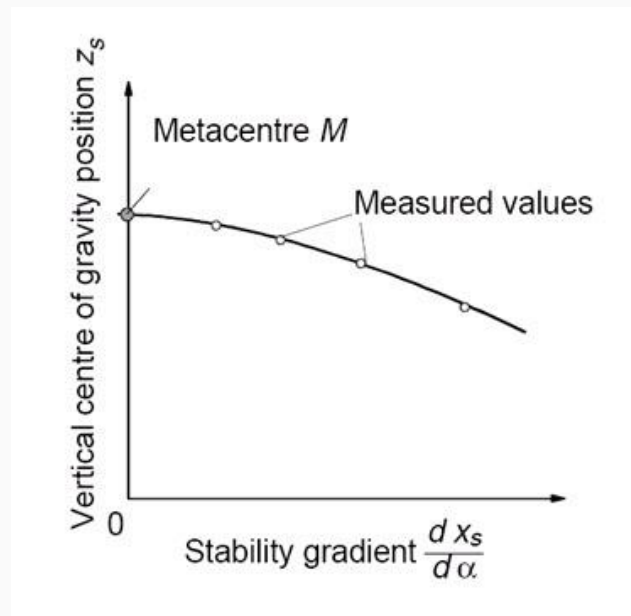
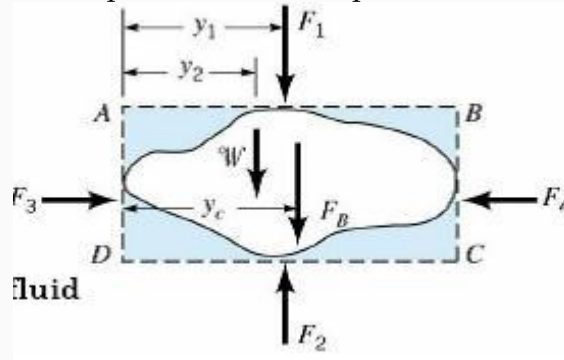

Figure 4- Graphical determination of metacenter

LESSON 9. ARCHIMEDES' PRINCIPLE

ARCHIMEDES' PRINCIPLE

- Archimedes' Principle states that the buoyant force has a magnitude equal to the weight of the fluid displaced by the body and is directed vertically upward.
- Buoyant force is a force that results from a floating or submerged body in a fluid.
- The force results from different pressures on the top and bottom of the object



$W$  is the weight of the shaded area

$F_1$  and  $F_2$  are the forces on the plane surfaces

$F_B$  is the buoyant force the body exerts on the fluid

The force of the fluid on the body is opposite, or vertically upward and is known as the Buoyant Force.

- The force is equal to the weight of the fluid it displaces.
- The buoyant forces acts through the centroid of the displaced volume

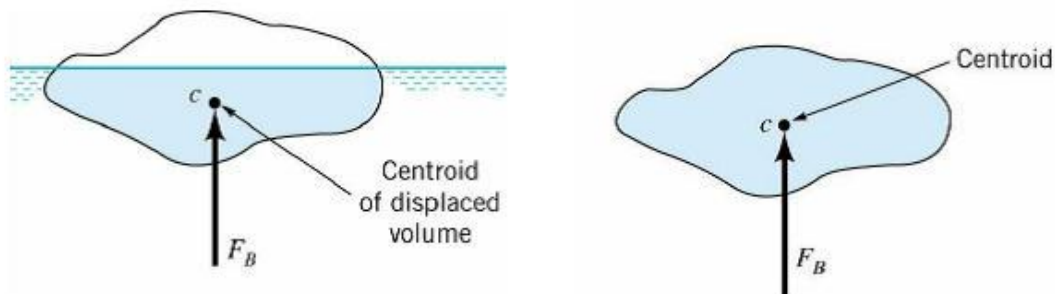

**The location is known as the center of buoyancy.**

Stable Equilibrium: if when displaced returns to equilibrium position.

Unstable Equilibrium: if when displaced it returns to a new equilibrium position.

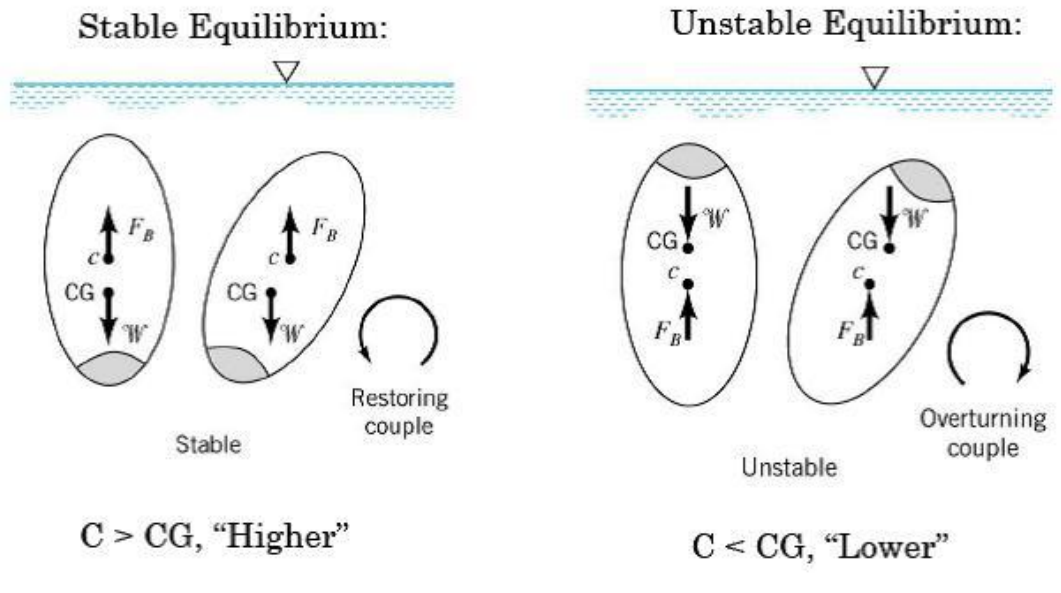

**STABILITY: SUBMERGED OBJECT**

- If the Centre of Gravity is below the centre of buoyancy this will be a righting moment and the body will tend to return to its equilibrium position (Stable).
- If the Centre of Gravity is above the centre of buoyancy, an over turning moment is produced and the body is unstable.
- **Note that,** As the body is totally submerged, the shape of displaced fluid is not altered when the body is tilted and so the centre of buoyancy unchanged relative to the body.



### MODULE 7. KINEMATICS OF FLUID FLOW

#### LESSON 10. FLUID KINEMATICS

##### 12.1 INTRODUCTION

##### WHAT IS FLUID KINEMATICS?

- Understanding how to study fluid motion from the kinematic point of view.
- Fluid kinematics deals with the motion of fluids without considering the forces and moments which create the motion
- Fluid kinematics includes:
  - Fluid motion which involves position, velocity and acceleration of fluid.
  - How to describe fluid motion?
    - Material derivative and its relationship to Lagrangian and Eulerian descriptions of fluid flow.
  - Flow visualization.
  - Plotting flow data.
  - Fundamental kinematic properties of fluid motion and deformation.
  - Reynolds Transport Theorem.

##### Method of describing Fluid motion

##### 12.2 Lagrangian Description

1. Lagrangian description of fluid flow tracks the position and velocity of individual particles.
  2. Based upon Newton's laws of motion.
  3. Difficult to use for practical flow analysis.
- Fluids are composed of *billions* of molecules.
  - Interaction between molecules hard to describe/model.
4. However, useful for specialized applications
    - Sprays, particles, bubble dynamics, rarefied gases.
    - Coupled Eulerian-Lagrangian methods.
  5. Named after Italian mathematician Joseph Louis Lagrange (1736-1813).

## 12.3 Eulerian Description

1. Eulerian description of fluid flow: a **flow domain** or **control volume** is defined by which fluid flows in and out.

2. We define **field variables** which are functions of space and time.

- Pressure field,  $P=P(x,y,z,t)$

- Velocity field,  $\vec{V}=\vec{V}(x,y,z,t)$

$$\vec{V} = u(x,y,z,t)\vec{i} + v(x,y,z,t)\vec{j} + w(x,y,z,t)\vec{k}$$

- Acceleration field,

$$\vec{a}=\vec{a}(x,y,z,t)$$

$$\vec{a} = a_x(x,y,z,t)\vec{i} + a_y(x,y,z,t)\vec{j} + a_z(x,y,z,t)\vec{k}$$

- These (and other) field variables define the flow field.

3. Well suited for formulation of initial boundary-value problems (PDE's).

4. Named after Swiss mathematician Leonhard Euler (1707-1783).

## 12.4 Coupled Eulerian-Lagrangian Method

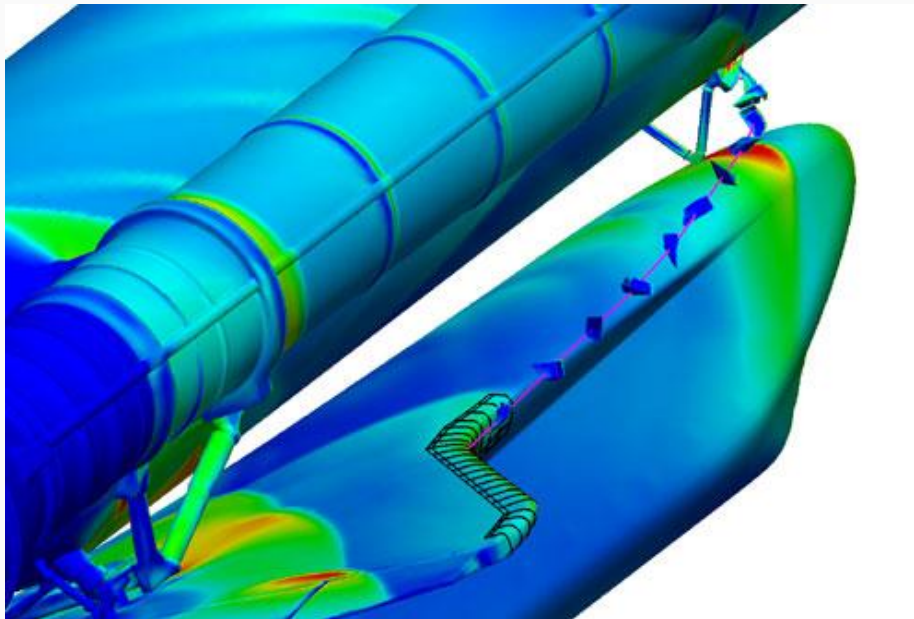

1. Forensic analysis of Columbia accident: simulation of shuttle debris trajectory using Eulerian CFD for flow field and Lagrangian method for the debris.

## 12.5 Acceleration Field

1. Consider a fluid particle and Newton's second law,

$$\vec{F}_{\text{particle}} = m_{\text{particle}} \vec{a}_{\text{particle}}$$

2. The acceleration of the particle is the time derivative of the particle's velocity.

$$\vec{a}_{\text{particle}} = \frac{d\vec{V}_{\text{particle}}}{dt}$$

## Fluids Mechanics

3. However, particle velocity at a point is the same as the fluid velocity,

$$\vec{V}_{\text{particle}} = \vec{V}(x_{\text{particle}}(t), y_{\text{particle}}(t), z_{\text{particle}}(t))$$

4. To take the time derivative of, chain rule must be used.

$$\vec{a}_{\text{particle}} = \frac{\partial \vec{V}}{\partial t} \frac{dt}{dt} + \frac{\partial \vec{V}}{\partial x} \frac{dx_{\text{particle}}}{dt} + \frac{\partial \vec{V}}{\partial y} \frac{dy_{\text{particle}}}{dt} + \frac{\partial \vec{V}}{\partial z} \frac{dz_{\text{particle}}}{dt}$$

5. Since

$$\frac{dx_{\text{particle}}}{dt} = u, \frac{dy_{\text{particle}}}{dt} = v, \frac{dz_{\text{particle}}}{dt} = w$$

$$\vec{a}_{\text{particle}} = \frac{\partial \vec{V}}{\partial t} + u \frac{\partial \vec{V}}{\partial x} + v \frac{\partial \vec{V}}{\partial y} + w \frac{\partial \vec{V}}{\partial z}$$

6. In vector form, the acceleration can be written as

$$\vec{a}(\mathbf{x}, y, z, t) = \frac{d\vec{V}}{dt} = \frac{\partial \vec{V}}{\partial t} + \left( \vec{V} \cdot \nabla \right) \vec{V}$$

7. First term is called the **local acceleration** and is nonzero only for unsteady flows.

8. Second term is called the **advective acceleration** and accounts for the effect of the fluid particle moving to a new location in the flow, where the velocity is different.

### 12.6 Material Derivative

1. The total derivative operator  $d/dt$  is called the material derivative and is often given special notation,  $D/Dt$ .

$$\left\{ \frac{D\vec{V}}{Dt} \right\} = \left\{ \frac{d\vec{V}}{dt} \right\} = \left\{ \frac{\partial \vec{V}}{\partial t} + \left( \vec{V} \cdot \nabla \right) \vec{V} \right\}$$

2. Advective acceleration is nonlinear: source of many phenomenon and primary challenge in solving fluid flow problems.

3. Provides "transformation" between Lagrangian and Eulerian frames.

4. Other names for the material derivative include: **total**, **particle**, **Lagrangian**, **Eulerian**, and **substantial** derivative.

### 12.7 Flow visualization

1. Flow visualization is the visual examination of flow-field features.

2. Important for both physical experiments and numerical (CFD) solutions.

3. Numerous methods

- Streamlines and streamtubes



## Fluids Mechanics

- Pathlines
- Streaklines
- Timelines
- Refractive techniques
- Surface flow techniques



## Lesson-11: FLOW VISUALIZATION

### 13.1 Types of FLUID flow

#### 13.1.1 Uniform flow

Flow velocity is the same magnitude and direction at every point in the fluid.

#### 13.1.2 Non-uniform flow

If at a given instant, the velocity is not the same at every point the flow. (In practice, by this definition, every fluid that flows near a solid boundary will be non-uniform - as the fluid at the boundary must take the speed of the boundary, usually zero. However if the size and shape of the of the cross-section of the stream of fluid is constant the flow is considered uniform.)

#### 13.1.3 Steady flow

A steady flow is one in which the conditions (velocity, pressure and cross-section) may differ from point to point but DO NOT change with time.

#### 13.1.4 Unsteady flow

If at any point in the fluid, the conditions change with time, the flow is described as unsteady. (In practice there is always slight variations in velocity and pressure, but if the average values are constant, the flow is considered steady.)

#### 13.1.5 Steady uniform flow

Conditions: do not change with position in the stream or with time.

Example: the flow of water in a pipe of constant diameter at constant velocity.

#### 13.1.6 Steady non-uniform flow

Conditions: change from point to point in the stream but do not change with time.

Example: flow in a tapering pipe with constant velocity at the inlet-velocity will change as you move along the length of the pipe toward the exit.

#### 13.1.7 Unsteady uniform flow

At a given instant in time the conditions at every point are the same, but will change with time.

Example: a pipe of constant diameter connected to a pump pumping at a constant rate which is then switched off.

#### 13.1.8 Unsteady non-uniform flow

Every condition of the flow may change from point to point and with time at every point.

## Fluids Mechanics

Example: waves in a channel.

### 13.1.9 Laminar flow

All the particles proceed along smooth parallel paths and all particles on any path will follow it without deviation.

Hence all particles have a velocity only in the direction of flow.

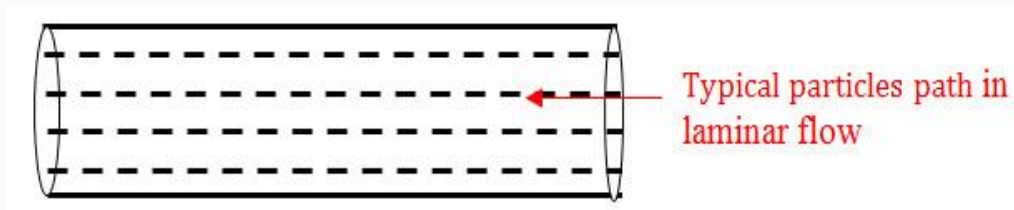

### 13.1.10 Turbulent Flow

The particles move in an irregular manner through the flow field.

Each particle has superimposed on its mean velocity fluctuating velocity components both transverse to and in the direction of the net flow.

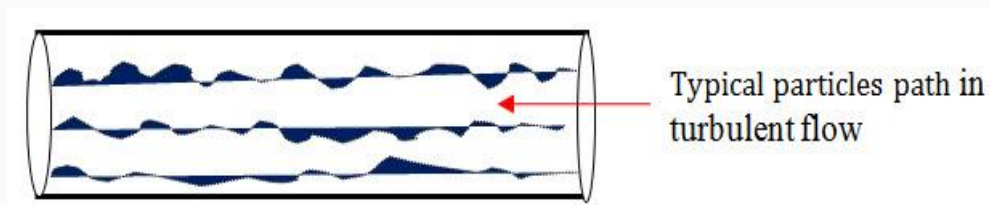

### 13.1.11 Transition Flow

- Exists between laminar and turbulent flow.
- In this region, the flow is very unpredictable and often changeable back and forth between laminar and turbulent states.
- Modern experimentation has demonstrated that this type of flow may comprise short 'burst' of turbulence embedded in a laminar flow.
- Rotational flow is the type of flow in which the fluid particles while flowing along streamlines also rotate about their own axis.
- Irrotational flow is the type of flow in which the fluid particles while flowing along streamlines do not rotate about their own axis.

### 13.1.12 Compressible or Incompressible flow

- All fluids are compressible - even water - their density will change as pressure changes.
- Under steady conditions, and provided that the changes in pressure are small, it is usually possible to simplify analysis of the flow by assuming it is incompressible and has constant density.

## Fluids Mechanics

- As you will appreciate, liquids are quite difficult to compress - so under most steady conditions they are treated as incompressible.

### 13.1.13 One, Two or Three-dimensional Flow

- In general, all fluids flow three-dimensionally, with pressures and velocities and other flow properties varying in all directions.
- In many cases the greatest changes only occur in two directions or even only in one.
- In these cases changes in the other direction can be effectively ignored making analysis much more simple.
- Flow is one dimensional if the flow parameters (such as velocity, pressure, depth etc.) at a given instant in time only vary in the direction of flow and not across the cross-section. The flow may be unsteady, in this case the parameter vary in time but still not across the cross-section.
- Flow is two-dimensional if it can be assumed that the flow parameters vary in the direction of flow and in one direction at right angles to this direction.

### 13.1.14 ROTATIONAL AND IRROTATIONAL FLOWS

- Rotational flow is the type of flow in which the fluid particles while flowing along streamlines also rotate about their own axis.
- Irrotational flow is the type of flow in which the fluid particles while flowing along streamlines do not rotate about their own axis.



Lesson-12: FLOW PATTERNS

14.1 Flow patterns

14.1.1 Streamlines

- In the study of fluid mechanics, streamlines are often drawn to visualize the flow field
- Streamline is a line that is everywhere tangent to the velocity vector at a given instant.

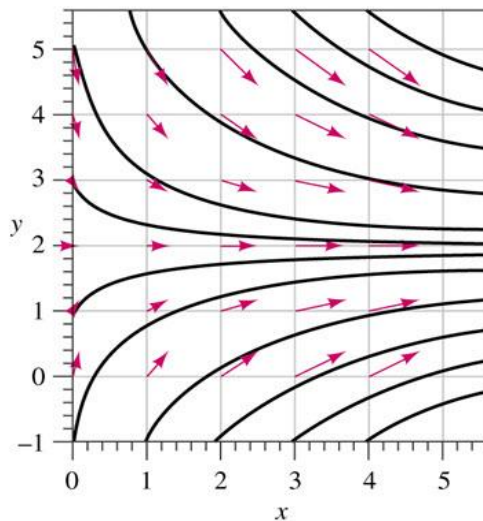
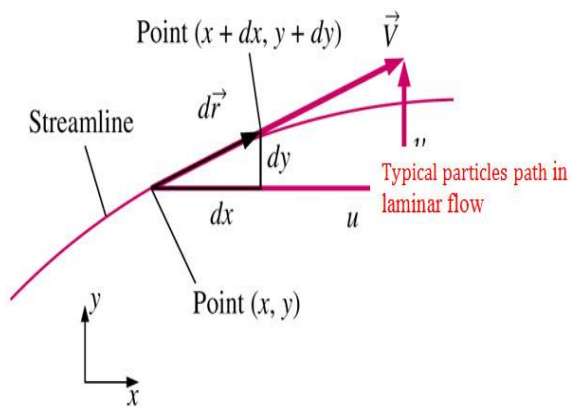
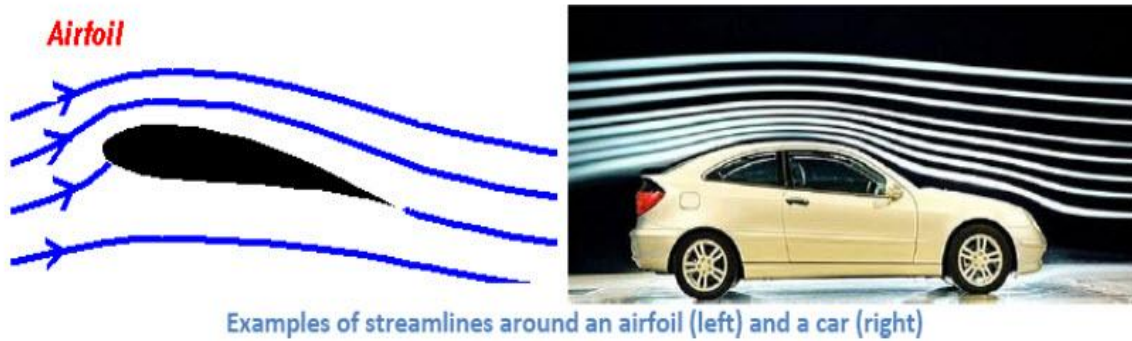

arc length

Consider an

$$d\vec{r} = dx\vec{i} + dy\vec{j} + dz\vec{k}$$

$d\vec{r}$  must be parallel to the local velocity vector

$$\vec{V} = u\vec{i} + v\vec{j} + w\vec{k}$$

Geometric arguments results in the equation for a streamline

$$\frac{dr}{V} = \frac{dx}{u} = \frac{dy}{v} = \frac{dz}{w}$$

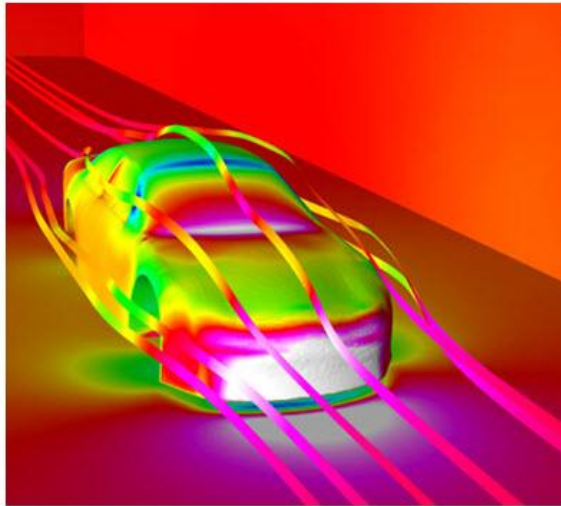

NASCAR surface pressure contours and streamlines

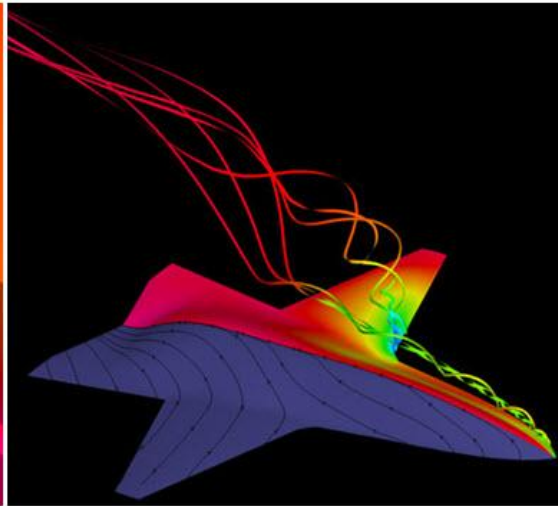

Airplane surface pressure contours, volume streamlines, and surface streamlines

### Stream Function

- Stream functions are for 2 dimensional flow only. In some fluid motion problems, this is a good enough approximation. Also, typically stream functions are used for incompressible flow, although a slightly modified version can be used for steady state compressible fluid flows also.
- In any case, for from the continuity equation, for incompressible fluids, for 2 dimensional flow:

Consider x and y co-ordinates (assuming the flow is not there in z direction).  $V_x$  and  $V_y$  are related by the DE. Hence we seek a function which can represent both. (i.e. we want to see if we can replace two functions by one, since they are related).

Assume

$$V_x = \frac{\partial \psi}{\partial y}$$

$$V_y = \int \left( -\frac{\partial V_x}{\partial x} \right) dy = \int \left( -\frac{\partial^2 \psi}{\partial x \partial y} \right) dy$$

$$= \int \left( -\frac{\partial^2 \psi}{\partial y \partial x} \right) dy = \left( -\frac{\partial \psi}{\partial x} \right)$$

- Instead of two functions,  $V_x$  and  $V_y$ , we need to solve for only one function  $\psi$  - Stream Function

## Fluids Mechanics

- Order of differential eqn increased by one
- The stream function is useful (a) as an aid in visualizing the fluid flow (b) as a mathematical tool in solving the fluid equations and obtaining the velocities, in some cases.
- The stream functions are the equations for stream lines. A fluid may not flow 'across' a streamline. It flows along the stream line. If a stream line's stream function value is X and another stream line's stream function value is Y, then the fluid flowing in the (imaginary) channel bounded by these two stream lines is given by X-Y (or Y-X, as appropriate!).
- Streamlines exist in 3D flow, but a corresponding stream function does not. (When we learn about velocity potentials, we can get an idea as to why). The stream lines in the 3D can be given by the equation:

$$\frac{dx}{V_x} = \frac{dy}{V_y} = \frac{dz}{V_z}$$

### 14.2.2 Pathlines

- A *pathline* is the actual path traveled by a given fluid particle.
- The actual path that a single fluid particle takes is referred to as the pathline, i.e., it is the trajectory of a particular fluid particle. This is referred to as the Lagrangian viewpoint of the flow field. Experimentally, it can be achieved by tagging a fluid particle and tracing its motion throughout the flow field.

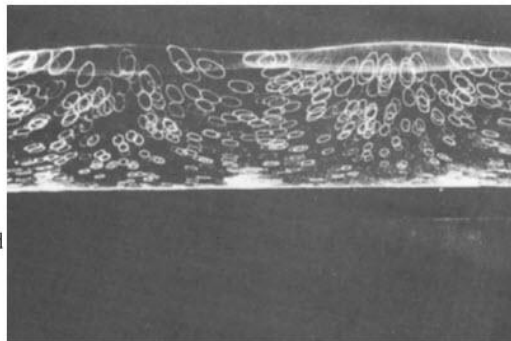
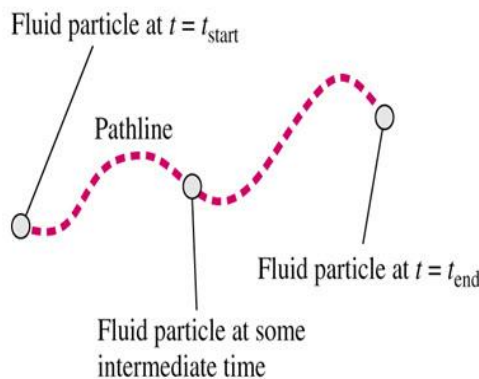

$$\left( x_{particle}(t), y_{particle}(t), z_{particle}(t) \right)$$

Particle location at time t:

$$\vec{x} = \vec{x}_{start} + \int_{t_{start}}^t \vec{V} dt$$

Particle Image Velocimetry (PIV) is a modern experimental technique to measure velocity field over a plane in the flow field.

### 14.2.3 streakline

- A *streakline* is the locus of particles which have earlier passed through a particular point.
- A particular type of fluid-material line which is of much utility is the *streakline*, which is the locus of all particles which have passed a specified ("tagging") location in some interval of time.
- The use of dye, smoke or hydrogen bubbles to generate streaklines is a technique that is often used in experiments to visualize the flow field.

#### *Streakline example:*

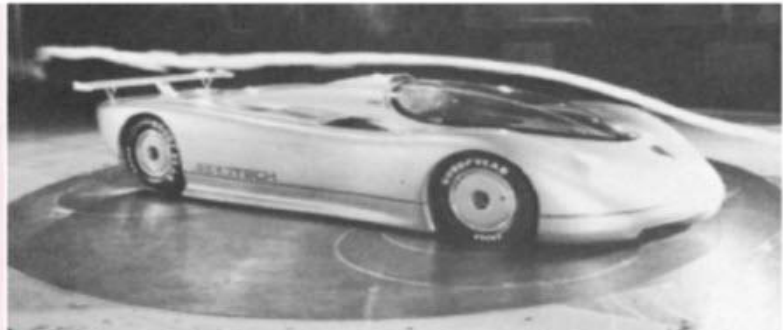
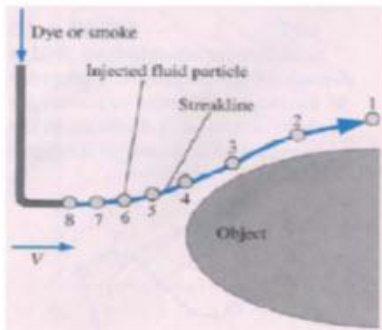

An illustration of streakline (left) and an example of streaklines, flow past a full-sized streamlined vehicle in the GM aerodynamics laboratory wind tunnel, and 18-ft by 34-ft test section facility by a 4000-hp, 43-ft-diameter fan (right)





MODULE 8: CIRCULATION AND VORTICITY

Lesson-13: CIRCULATION AND VORTICITY

15.1 Circulation, Vorticity and rotation in fluid

- Circulation can be considered as the amount of force that pushes along a closed boundary or path.
- Circulation is the total “push” you get when going along a path, such as a circle.

The *circulation*,  $C$ , about a closed contour in a fluid is defined as the line integral evaluated along the contour of the component of the velocity vector that is locally tangent to the contour.

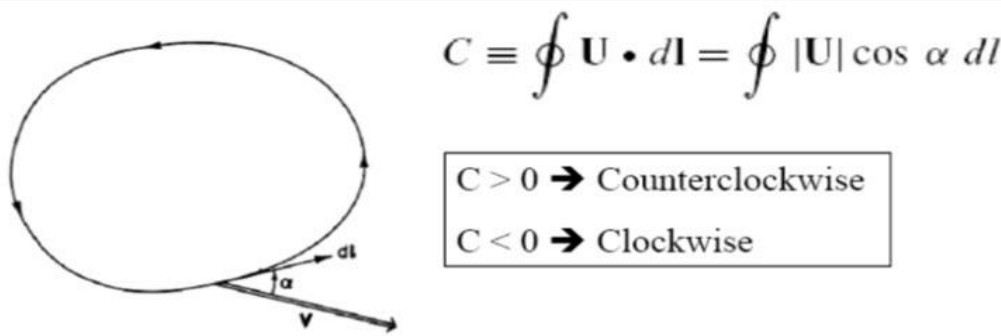

Figure 1: Circulation contour

- One of the difficulties of working with momentum (or velocity) of a parcel in fluid mechanics stems from the pressure forces to which the parcel is subjected, which are continuously changing the parcel’s momentum in complicated ways (since pressure is not fixed, but itself evolves with the flow).
- However, while pressure gradients can change a parcel’s momentum, they cannot change its spin, at least in certain simple situations. Consider two-dimensional, inviscid flow of an incompressible fluid:

$$\frac{du}{dt} = -\frac{1}{\rho_0} \frac{\partial p}{\partial x} ; \quad \frac{dv}{dt} = -\frac{1}{\rho_0} \frac{\partial p}{\partial y} ; \quad \frac{\partial u}{\partial x} + \frac{\partial v}{\partial y} = 0 . \quad (1)$$

If we take the curl of the momentum equations, the pressure gradient term disappears. So, by taking  $\frac{\partial}{\partial x}$  of the second of (1) minus  $\frac{\partial}{\partial y}$  of the first, we get

$$\frac{\partial}{\partial x} \left( \frac{dv}{dt} \right) - \frac{\partial}{\partial y} \left( \frac{du}{dt} \right) = 0 . \quad (2)$$

## Fluids Mechanics

Moreover, a little mathematical juggling [expand the total derivatives, and use the 3rd of (1)] shows that

$$\frac{\partial}{\partial x} \left( \frac{dv}{dt} \right) - \frac{\partial}{\partial y} \left( \frac{du}{dt} \right) = \frac{d}{dt} \left( \frac{\partial v}{\partial x} - \frac{\partial u}{\partial y} \right)$$

The term inside the bracket on the RHS is the vertical component of the vorticity, defined in general by

$$\boldsymbol{\xi} = \nabla \times \mathbf{u} ; \quad (3)$$

its vertical component is

$$\zeta = \frac{\partial v}{\partial x} - \frac{\partial u}{\partial y} . \quad (4)$$

Since the flow in this barotropic problem lies within horizontal planes, only the vertical component is nontrivial.

The vorticity is a local measure of the spin of the fluid motion. For example if the fluid (relative to the rotating frame, remember) is in solid body rotation about the origin with angular frequency  $\omega$ , then (see Fig. 2)

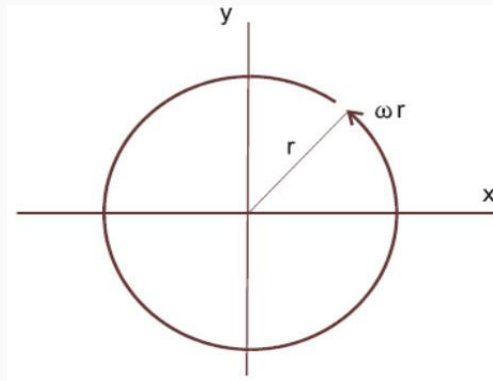

Figure 2: Rotation about the origin; the velocity at position  $\mathbf{r} = (x, y)$  is  $\mathbf{U} = \omega \mathbf{r}$ .

$$u = -\omega y; v = \omega x ;$$

so the vorticity twice the rotation rate (anticlockwise being positive). [In fact, we can now see that the Coriolis parameter

$$f = 2\Omega \sin \varphi$$

is just the planetary vorticity - the vertical component associated with the planetary rotation] But vorticity does not have to involve circular flow. A linear shear flow

$$u = \gamma y ; v = 0$$

has vorticity  $\zeta = -\gamma$ .

To return to (2), then, we have

$$\frac{d\zeta}{dt} = 0 \quad (5)$$

This equation states that the time derivative following the motion of the vorticity is (in this simple case) zero. Therefore: In inviscid two-dimensional flow, the vorticity is conserved following the motion.

### 15.2 Measurement of Rotation

- Circulation and vorticity are the two primary measures of rotation in a fluid.
- Circulation, which is a scalar integral quantity, is a *macroscopic* measure of rotation for a finite area of the fluid.
- Vorticity, however, is a vector field that gives a *microscopic* measure of the rotation at any point in the fluid.

Because of shear in the fluid, during flow, an element may not only get translated, but also 'rotated'. The rotation R is given by :

$$R = \omega_z = \frac{d}{dt} \left( \frac{\alpha + \beta}{2} \right)$$

### 15.3 Solid Body Rotation

- In fluid mechanics, the state when no part of the fluid has motion relative to any other part of the fluid is called 'solid body rotation'.
- If the viscosity of the fluid is zero, the rotation will be zero. It does not mean that the flow is 'straight' and not via a circular path; for example, the fluid motion in a centrifuge can be irrotational.
- All real fluids have viscosity and the motion is never truly irrotational with few exceptions (Even in the exception, it doesn't mean that viscosity is zero, but it means that the problem is defined suitably. Consider the example of an airplane flying in still air. If you take the plane as reference, then the air far away from the plane moves at velocity of  $-V$ , but with out feeling viscosity). The equations are useful in obtaining solutions which are good enough in some circumstances. They are also (relatively) easily solvable.
- If a flow is irrotational, the stream function satisfies the Laplace equation. Otherwise, it is given by the Poisson Equation.
- In case the flow is irrotational, it is also called potential flow. The reason is, irrotational flow can be represented as a flow 'perpendicular' to lines of equal potentials. (for example, in

## Fluids Mechanics

electricity, there is no current between points of equal potentials. There is flow of current from a point of higher potential to point of lower potential). The fluid flows from a point of higher potential to a point of lower potential.

- Vorticity is the tendency for elements of the fluid to "spin".
- Vorticity can be related to the amount of "circulation" or "rotation" (or more strictly, the local angular rate of rotation) in a fluid.

### 15.4 Vorticity

- Vorticity is the tendency for elements of the fluid to "spin".
- Vorticity can be related to the amount of "circulation" or "rotation" (or more strictly, the local angular rate of rotation) in a fluid.

Definition:

$$\text{Absolute Vorticity} \rightarrow \omega_a \equiv \nabla \times \mathbf{U}_a$$

$$\text{Relative Vorticity} \rightarrow \omega \equiv \nabla \times \mathbf{U}$$

$$\omega = \left( \frac{\partial w}{\partial y} - \frac{\partial v}{\partial z}, \frac{\partial u}{\partial z} - \frac{\partial w}{\partial x}, \frac{\partial v}{\partial x} - \frac{\partial u}{\partial y} \right)$$

### 15.6.2 "Depth" of Potential Vorticity

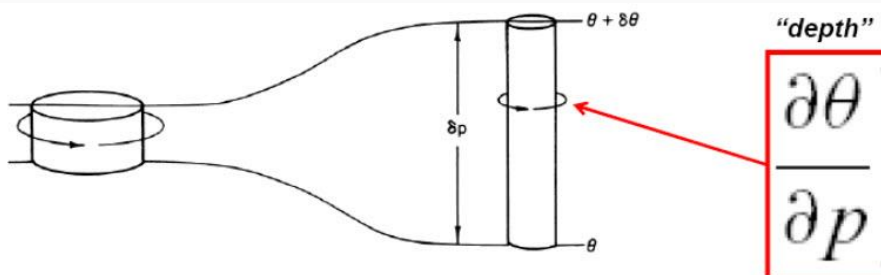

Figure 2: A cylindrical column of air moving adiabatically conserving potential vorticity

### 15.5 Stoke's Theorem

$$\oint \mathbf{U} \cdot d\mathbf{l} = \iint_A (\nabla \times \mathbf{U}) \cdot \mathbf{n} dA$$

- Stokes' theorem states that the circulation about any closed loop is equal to the integral of the normal component of vorticity over the area enclosed by the contour.
- For a finite area, circulation divided by area gives the *average* normal component of vorticity in the region.
- Vorticity may thus be regarded as a measure of the local fluid angular velocity of the fluid.

15.6 Vorticity in Natural Coordinate

- Vorticity can be associated with only two broad types of flow configuration.
- It is easier to demonstrate this by considering the vertical component of vorticity in natural coordinates

$$\delta C = V[\delta s + d(\delta s)] - \left( V + \frac{\partial V}{\partial n} \delta n \right) \delta s$$

$$d(\delta s) = \delta \beta \delta n$$

$$\delta C = \left( -\frac{\partial V}{\partial n} + V \frac{\delta \beta}{\delta s} \right) \delta n \delta s$$

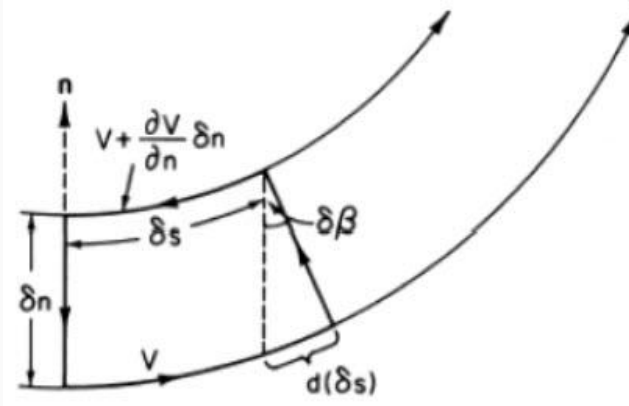

$$\zeta = \lim_{\delta n, \delta s \rightarrow 0} \frac{\delta C}{(\delta n \delta s)} = -\frac{\partial V}{\partial n} + \frac{V}{R_s}$$

Shear Vorticity
Curvature Vorticity

15.7 Ertel's Potential Vorticity

The quantity P [units: K kg<sup>-1</sup> m<sup>2</sup> s<sup>-1</sup>] is the isentropic coordinate form of *Ertel's potential vorticity*.

$$P \equiv (\zeta_\theta + f) \left( -g \frac{\partial \theta}{\partial p} \right)$$

- It is defined with a minus sign so that its value is normally positive in the Northern Hemisphere.
- Potential vorticity is often expressed in the potential vorticity unit (PVU), where 1 PVU = 10<sup>-6</sup> K kg<sup>-1</sup> m<sup>2</sup> s<sup>-1</sup>.
- Potential vorticity is always in some sense a measure of the ratio of the absolute vorticity to the **effective depth of the vortex**.

## Fluids Mechanics

- The effective depth is just the differential distance between potential temperature surfaces measured in pressure units ( $-\partial\theta/\partial p$ )

### 15.8 Depth and Latitude

- The Rossby potential vorticity conservation law indicates that in a barotropic fluid, a change in the depth is dynamically analogous to a change in the Coriolis parameter.
- Therefore, in a barotropic fluid, a decrease of depth with increasing latitude has the same effect on the relative vorticity as the increase of the Coriolis force with latitude.

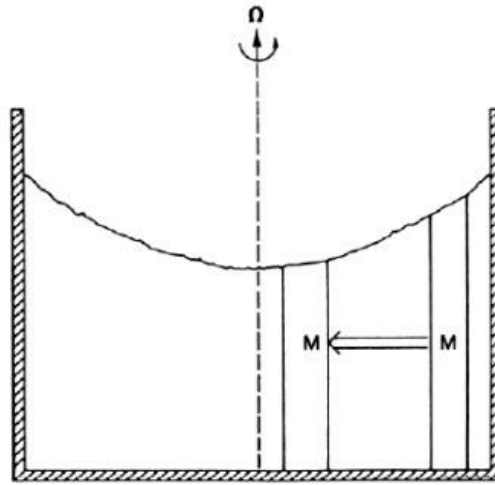

### 15.9 Velocity Potential

- A velocity potential is used in fluid dynamics when a fluid occupies a simply connected region and is irrotational.
- The potential is related to the velocity components. Equations describing the velocity potential.



### MODULE 9. FLOWNET

#### Lesson-14: FLOWNET

##### 16.1.1 FLOW NETS FOR HOMOGENEOUS ISOTROPIC SYSTEMS

A flow net is a graphical solution to the equations of steady fluid flow. A flow net consists of two sets of lines which must always be orthogonal (perpendicular to each other): flow lines, which show the direction of groundwater flow, and equipotentials (lines of constant head), which show the distribution of potential energy.

Flow nets are usually constructed through trial-and-error sketching.

##### To construct a flow net:

1. make a two-dimensional scale drawing of the system under consideration (usually a profile, but may be a map view.)
  2. determine or specify the boundary conditions, i.e., indicate/label the position of the water table, of any impermeable boundaries, of any points of known head or known pressure.
    - a. any surface of constant head (e.g., bottom of a flat-bottomed reservoir) is by definition an equipotential, and flow lines must meet it at right angles.
    - b. since flow cannot cross impermeable boundaries, the flow at such a boundary must be parallel to it, i.e., impermeable boundaries are flow lines, and equipotentials must meet them at right angles.
    - c. the water table is, by definition, the surface where  $P = 0$ ; it can thus be an equipotential only if it is horizontal. At any point on the water table (no matter whether it is flat or sloping)  $h = z$ , where  $z$  is the elevation of the water table above the datum.
- If there is no seepage percolating down to the water table, it can be considered a flow line. In the general case however (sloping water table, seepage across it), the water table is neither a flow line nor an equipotential, and flow lines will intersect it at an angle.
3. Once you have defined the boundary conditions, start trial sketching of flow lines and equipotentials, following the rules in step 2 above, and being sure that the flow lines and equipotentials always intersect at right angles.

Try to make the flow net consist of curvilinear "squares", i.e., the boxes in the flow net may have curving sides, but the midline lengths of the "square" should be approximately equal. (arrows inside square in diagram below) This is especially important if the flow net is to be used for calculations of groundwater discharge.

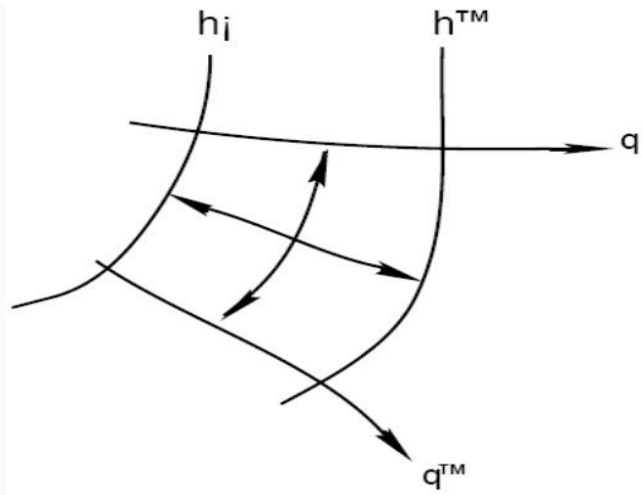

Keep sketching and refining until you have a good set of "squares" which satisfies the boundary conditions.

4. Determine the head at the left-most and right-most equipotentials and subtract them to get  $\Delta h$ , the total head difference across the net. Now determine  $N_d$ , the number of potential drops (i.e., squares) between these two equipotentials. The value of each potential drop is thus:

$$h_d = \frac{\Delta h}{N_d}$$

Knowing this, you can label each equipotential with its correct value of  $h$ .

5. To determine pore pressure at any point on an equipotential  $h$ , simply measure the elevation,  $z$ , of the point above the datum. Then the pressure is given by:

$p = (h - z)\gamma$  where  $\gamma$  is the specific weight of water.





MODULE 10. CONTINUITY EQUATION

Lesson-15: CONTINUITY EQUATION

17.1 Principle of conservation of mass

Let us consider a material volume  $V$  with bounding surface  $S$ . The principle of conservation of mass imposes that: the material derivative of the mass of fluid in  $V$  is equal to zero.

The mass of the fluid in  $V$  is given by

$$\iiint_V \rho dV.$$

$$\frac{D}{Dt} \iiint_V \rho dV = 0.$$

$$\iiint_V \frac{\partial \rho}{\partial t} + \nabla \cdot (\rho \mathbf{u}) dV = 0.$$

since the volume  $V$  is arbitrary the following differential equation holds

$$\frac{\partial \rho}{\partial t} + \nabla \cdot (\rho \mathbf{u}) = 0, \quad \text{or, in index notation,} \quad \frac{\partial \rho}{\partial t} + \frac{\partial}{\partial x_j} (\rho u_j) = 0.$$

This equation is known in fluid mechanics as continuity equation.

In the particular case in which the fluid is incompressible, i.e. the density  $\rho$  is constant, the above equation reduces to

$$\nabla \cdot \mathbf{u} = 0, \quad \text{or, in index notation,} \quad \frac{\partial u_j}{\partial x_j} = 0.$$

This implies that the velocity field of an incompressible fluid is divergence free.

17.2 CONTINUITY EQUATION

Rate of flow or discharge ( $Q$ ) is the volume of fluid flowing per second. For incompressible fluids flowing across a section,

Volume flow rate,

$$Q = AV \text{ m}^3/\text{s}$$

## Fluids Mechanics

where

A=cross sectional area and

V= average velocity.

For compressible fluids, rate of flow is expressed as mass of fluid flowing across a section per second.

Mass flow rate (m) = $(\rho AV)$  kg/s where  $\rho$  = density.

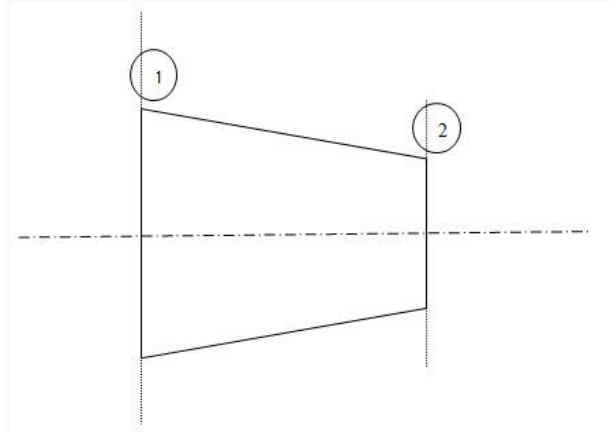

Continuity equation is based on Law of Conservation of Mass. For a fluid flowing through a pipe, in a steady flow, the quantity of fluid flowing per second at all cross-sections is a constant.

Let  $v_1$ =average velocity at section [1],

$r_1$ =density of fluid at [1],  $A_1$ =area of flow at [1];

Let  $v_2, r_2, A_2$  be corresponding values at section [2].

Rate of flow at section [1]=  $r_1 A_1 v_1$

Rate of flow at section [2]=  $r_2 A_2 v_2$

$$r_1 A_1 v_1 = r_2 A_2 v_2$$

This equation is applicable to steady compressible or incompressible fluid flows and is called Continuity Equation.

If the fluid is incompressible,  $r_1 = r_2$  and the continuity equation reduces to  $A_1 v_1 = A_2 v_2$

For steady, one dimensional flow with one inlet and one outlet:

$$r_1 A_1 v_1 - r_2 A_2 v_2 = 0$$

For control volume with N inlets and outlets

$$\sum_{i=1}^N (A_i V_i) = 0$$

## Fluids Mechanics

where inflows are positive and outflows are negative .

Velocities are normal to the areas. This is the continuity equation for steady one dimensional flow through a fixed control volume

When density is constant,

$$\sum_{i=1}^N (A_i V_i) = 0$$

### 17.3 Momentum equation in integral form

Let us consider a material volume  $V$  with bounding surface  $S$ . Newton's first principle states that: the material derivative of the momentum of the fluid in  $V$  is equal to the resultant of all external forces acting on the volume.

The momentum of the fluid in  $V$  is given by:

$$\iiint_V \rho \mathbf{u} dV.$$

Therefore we have (in index notation):

$$\frac{D}{Dt} \iiint_V \rho u_i dV = \iiint_V \rho f_i dV + \iint_S t_i dS.$$
$$\iiint_V \frac{\partial}{\partial t} (\rho u_i) dV + \iint_S \rho u_i u_j n_j dS = \iiint_V \rho f_i dV + \iint_S t_i dS.$$

This is the integral form of the momentum equation and is often written in compact form as:

$$I + W = F + \Sigma,$$

with  $I$  named local inertia and  $W$  being the flux of momentum across  $S$ .



### MODULE 11, 12. FLUID DYNAMICS

#### LESSON 16. DYNAMICS OF FLUID FLOW

##### Fluids in Motion

- Moving fluids whose density doesn't change and those are at steady state.
- There are two main relationships:
  - Continuity equation
  - Bernouli's equation
- By steady state, the pressure and velocity do not change in time in the fluid, although they may change with position.
- For fluids at rest, we only needed to consider two quantities, density and pressure.
- If the fluid is flowing (or moving) we need one more quantity, the velocity of the fluid.
- There are three quantities to be consider in a fluid:
  - density
  - pressure
  - velocity

##### Continuity Equation

Consider a fluid that is flowing through a pipe. The pipe has a cross sectional area that is not constant. Let the area on the left end of the pipe be  $A_1$  and the area on the right end be  $A_2$ . Let the velocity of the fluid entering the pipe from the left be labeled  $V_1$  and the velocity of the fluid leaving the pipe from the right be  $V_2$ .

If the fluid is incompressible,

$$\text{Volume entering} = \text{Volume leaving}$$

$$A_1V_1 = A_2V_2$$

If  $A_2$  is smaller than  $A_1$ , then  $V_2$  must be larger than  $V_1$  so the amount of water coming out equals the amount going in.

##### Bernouli's Equation

###### 5.1 Frictionless Flow Along Streamlines

## Fluids Mechanics

- Application of the second Newton's law of motion along streamlines of fluid flow leads to a very famous equation in Fluid Mechanics, i.e. the Bernoulli equation.
- There are four assumptions used to derive the equation and these four assumptions must always be remembered to ensure that it is used correctly, i.e.

1. The flow is inviscid or frictionless, i.e. viscous effects are negligible which is valid for low viscosity fluids such as water and air,
2. The flow is steady, i.e. the flow pattern is fully developed and does not change with time,
3. The flow is incompressible, which is valid for all fluids and low speed gas of Mach 0.3 or below since the change in gas density is less than 5%,
4. The flow considered is along the same streamline, as the variation of properties for fluid molecules travelling in the same path can be simulated more accurately through conservation laws of physics.

- In fluid dynamics, Bernoulli's principle states that for an inviscid flow, an increase in the speed of the fluid occurs simultaneously with a decrease in pressure or a decrease in the fluid's potential energy.
- Bernoulli's principle is named after the Swiss scientist Daniel Bernoulli who published his principle in his book Hydrodynamica in 1738.
- Bernoulli's principle can be applied to various types of fluid flow, resulting in what is loosely denoted as Bernoulli's equation. In fact, there are different forms of the Bernoulli equation for different types of flow.
- The simple form of Bernoulli's principle is valid for incompressible flows (e.g. most liquid flows) and also for compressible flows (e.g. gases) moving at low Mach numbers. More advanced forms may in some cases be applied to compressible flows at higher Mach numbers (see the derivations of the Bernoulli equation).
- Bernoulli's principle can be derived from the principle of conservation of energy. This states that, in a steady flow, the sum of all forms of mechanical energy in a fluid along a streamline is the same at all points on that streamline. This requires that the sum of kinetic energy and potential energy remain constant. Thus an increase in the speed of the fluid occurs proportionately with an increase in both its dynamic pressure and kinetic energy, and a decrease in its static pressure and potential energy. If the fluid is flowing out of a reservoir, the sum of all forms of energy is the same on all streamlines because in a reservoir the energy per unit volume (the sum of pressure and gravitational potential  $\rho gh$ ) is the same everywhere.

In most flows of liquids, and of gases at low Mach number, the density of a fluid parcel can be considered to be constant, regardless of pressure variations in the flow. Therefore, the fluid can be considered to be incompressible and these flows are called incompressible flow. Bernoulli performed his experiments on liquids, so his equation in its original form is valid only for incompressible flow. A common form of Bernoulli's equation, valid at any arbitrary point along a streamline, is:

$$\frac{v^2}{2} + gz + \frac{p}{\rho} = \text{constant}$$

Where :

## Fluids Mechanics

$v$  is the fluid flow speed at a point on a streamline,

$g$  is the acceleration due to gravity,

$z$  is the elevation of the point above a reference plane, with the positive  $z$ -direction pointing upward – so in the direction opposite to the gravitational acceleration,

$P$  is the pressure at the chosen point, and

$\rho$  is the density of the fluid at all points in the fluid.

For conservative force fields, Bernoulli's equation can be generalized as:<sup>[8]</sup>

$$\frac{v^2}{2} + \Psi + \frac{p}{\rho} = \text{constant}$$

where  $\Psi$  is the force potential at the point considered on the streamline. *E.g.* for the Earth's gravity  $\Psi = gz$ .

The following two assumptions must be met for this Bernoulli equation to apply:

- the flow must be incompressible – even though pressure varies, the density must remain constant along a streamline;
- friction by viscous forces has to be negligible.

By multiplying with the fluid density, equation (A) can be rewritten as:

$$\frac{1}{2} \rho v^2 + \rho g z + p = \text{constant}$$

or:

$$q + \rho g h = p_0 + \rho g z = \text{constant}$$

where:

$q = \frac{1}{2} \rho v^2$  is dynamic pressure,

$h = z + \frac{p}{\rho g}$  is the piezometric head or hydraulic head (the sum of the elevation  $z$  and the pressure head) and

$p_0 = p + q$  is the total pressure (the sum of the static pressure  $p$  and dynamic pressure  $q$ ).

The constant in the Bernoulli equation can be normalized. A common approach is in terms of **total head** or **energy head**  $H$ :

$$H = z + \frac{p}{\rho g} + \frac{v^2}{2g} = h + \frac{v^2}{2g},$$

The above equations suggest there is a flow speed at which pressure is zero, and at even higher speeds the pressure is negative. Most often, gases and liquids are not capable of negative absolute pressure, or even zero pressure, so clearly Bernoulli's equation ceases to be valid before zero pressure

## Fluids Mechanics

is reached. In liquids – when the pressure becomes too low – cavitation occurs. The above equations use a linear relationship between flow speed squared and pressure. At higher flow speeds in gases, or for sound waves in liquid, the changes in mass density become significant so that the assumption of constant density is invalid.

Final Ideas:

- Bernoulli's equation states that if one moves around in the fluid, points of fast velocity are points of low pressure, and points of lower speed have higher pressure. This does make "sense", since to obtain a large velocity places of larger pressure somewhere else are needed to "push" the fluid to these higher speeds where the pressure is lower.
- If the fluid is at rest, velocity is zero everywhere, and Bernoulli's equation reduces to the equation for a fluid at rest:  $P + \rho gz = \text{constant}$ .

## Energy and Hydraulic Grade Lines

- **Static pressure**  $p$  – representing the actual or thermodynamic pressure at a particular point in the streamline.
- **Dynamic pressure**  $\frac{1}{2}\rho V^2$  – representing the kinetic energy for fluid molecules passing at the same point.
- **Hydrostatic pressure**  $\rho gz$  – representing the potential energy for fluid molecules at the same point which changes with elevation.
- If the fluid has a certain velocity  $V$  travelling along one streamline with small elevation, the hydrostatic pressure is usually small and insignificant compared to the static pressure and the dynamic pressure. The combination of the static pressure and the dynamic pressure forms the stagnation pressure  $p_0$ , or

$$p + \frac{1}{2}\rho V^2 = p_0$$



## LESSON 17. APPLICATIONS OF BERNOULLI'S EQUATION

### Physical interpretation of Bernoulli equation

- Integration of the equation of motion to give the Bernoulli equation actually corresponds to the work-energy principle often used in the study of dynamics.
- This principle results from a general integration of the equations of motion for an object in a very similar to that done for the fluid particle.
- With certain assumptions, a statement of the work-energy principle may be written as follows:
  - The work done on a particle by all forces acting on the particle is equal to the change of the kinetic energy of the particle.
  - The Bernoulli equation is a mathematical statement of this principle.
  - In fact, an alternate method of deriving the Bernoulli equation is to use the first and second laws of thermodynamics (the energy and entropy equations), rather than Newton's second law. With the approach restrictions, the general energy equation reduces to the Bernoulli equation.

An alternate but equivalent form of the Bernoulli equation is:

$$\frac{p}{\gamma} + \frac{V^2}{2g} + z = \text{constant}$$

Along a streamline:

Pressure head:

$$\frac{p}{\gamma}$$

Velocity head:

$$\frac{V^2}{2g}$$

Elevation head:

$$Z$$

The Bernoulli equation states that the sum of the pressure head, the velocity head, and the elevation head is constant along a streamline.



## Fluids Mechanics

### Static, Stagnation, Dynamic, and Total Pressure

$$p + \frac{1}{2}\rho V^2 + \gamma z = p_T = \text{constant}$$

Along a streamline:

Static pressure:

$$p$$

Dynamic pressure:

$$\frac{1}{2}\rho V^2$$

Hydrostatic pressure:

$$\gamma z$$

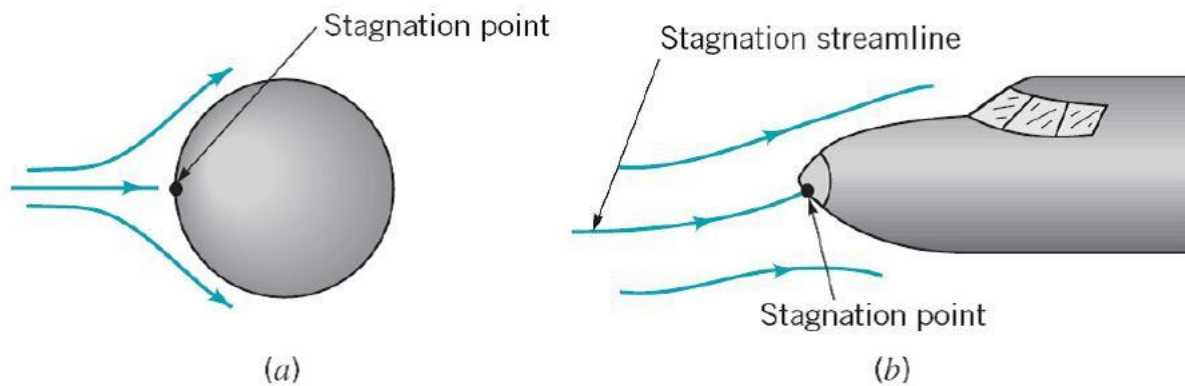

Stagnation points on bodies in flowing fluids.

Stagnation pressure:

$$p + \frac{1}{2}\rho V^2$$

(assuming elevation effects are negligible) where  $p$  and  $V$  are the pressure and velocity of the fluid upstream of stagnation point. At stagnation point, fluid velocity  $V$  becomes zero and all of the kinetic energy converts into a pressure rise.

Total pressure:

$$p_T = p + \frac{1}{2}\rho V^2 + \gamma z$$

(along a streamline)

Applications of Bernoulli Equation

1) Stagnation Tube

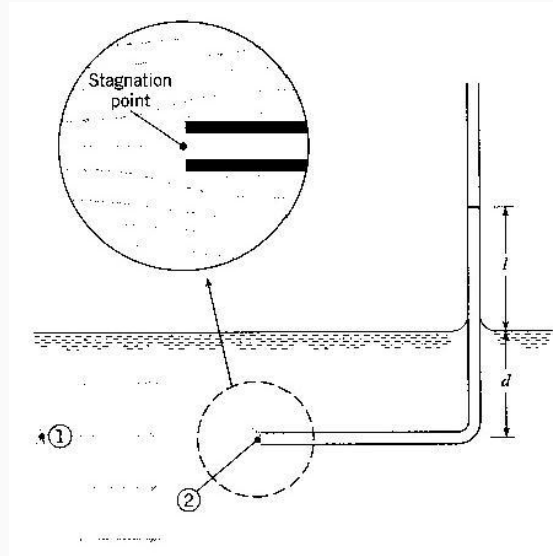

$$p_1 + \rho \frac{V_1^2}{2} = p_2 + \rho \frac{V_2^2}{2}$$

$$V_1^2 = \frac{2}{\rho} (p_2 - p_1)$$

$$= \frac{2}{\rho} (\gamma l)$$

$$V_1 = \sqrt{2gl}$$

$$z_1 = z_2$$

$$p_1 = \gamma d, \quad V_2 = 0$$

$$p_2 = \gamma(l + d) \text{ gage}$$

Limited by length of tube and need for free surface reference

2) Pitot Tube

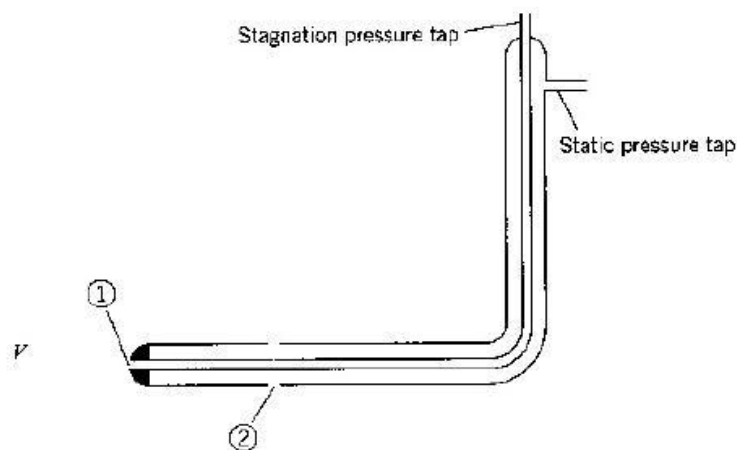

## Fluids Mechanics

$$\frac{p_1}{\gamma} + \frac{V_1^2}{2g} + z_1 = \frac{p_2}{\gamma} + \frac{V_2^2}{2g} + z_2 \quad V_2 = \left\{ 2g \left[ \left( \frac{p_1}{\gamma} + z_1 \right) - \left( \frac{p_2}{\gamma} + z_2 \right) \right] \right\}^{\frac{1}{2}}$$

where,

$V_1 = 0$  and  $h =$  piezometric head

$$V = V_2 = \sqrt{2g(h_1 - h_2)}$$

$h_1 - h_2$

from manometer or pressure gage

For gas flow

$$\Delta p / \gamma \gg \Delta z$$

$$V = \sqrt{\frac{2\Delta p}{\rho}}$$

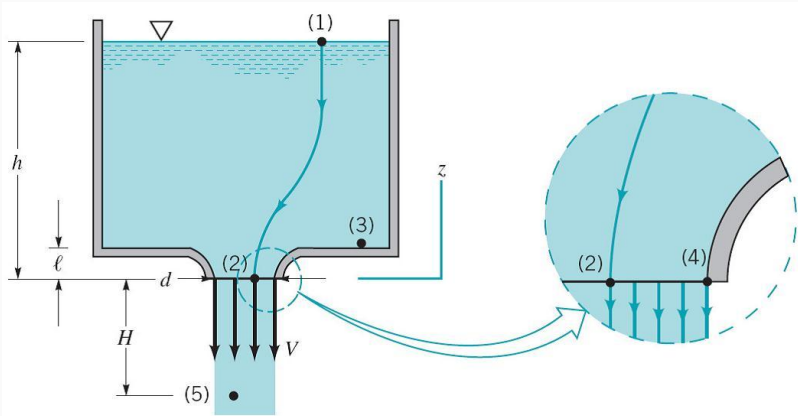

Application of Bernoulli equation between points (1) and (2) on the streamline

shown gives

$$p_1 + \frac{1}{2}\rho V_1^2 + \gamma z_1 = p_2 + \frac{1}{2}\rho V_2^2 + \gamma z_2$$

Since  $z_1 = h$ ,  $z_2 = 0$ ,  $V_1 \approx 0$ ,  $p_1 = 0$ ,  $p_2 = 0$ , we have

$$\gamma h = \frac{1}{2}\rho V_2^2$$

$$V_2 = \sqrt{2 \frac{\gamma h}{\rho}} = \sqrt{2gh}$$

Bernoulli equation between points (1) and (5) gives

$$V_5 = \sqrt{2g(h + H)}$$

### 3) Simplified form of the continuity equation

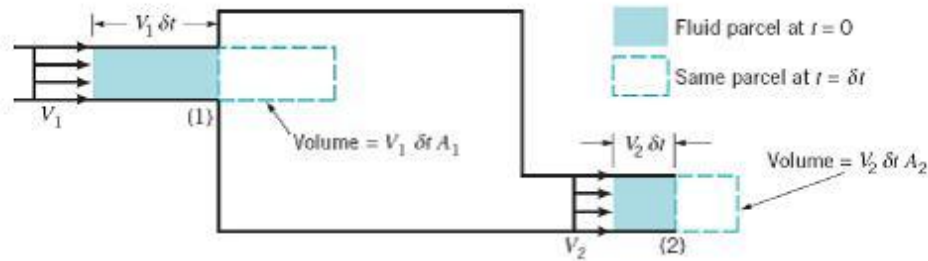

Steady flow into and out of a tank

Obtained from the following intuitive arguments:

Volume flow rate:  $Q = VA$

Mass flow rate:  $\dot{m} = \rho Q = \rho VA$

Conservation of mass requires

$$\rho_1 V_1 A_1 = \rho_2 V_2 A_2$$

For incompressible flow  $\rho_1 = \rho_2$ , we have

$$V_1 A_1 = V_2 A_2$$

or

$$Q_1 = Q_2$$



LESSON 18. VENTURIMETER, ORIFICEMETER AND NOZZLE, SIPHON FLOWRATE MEASUREMENT

venturimeter

- The Venturi meter is a device for measuring discharge in a pipe.
- It is a rapidly converging section which increases the velocity of flow and hence reduces the pressure.
- It then returns to the original dimensions of the pipe by a gently diverging 'diffuser' section.

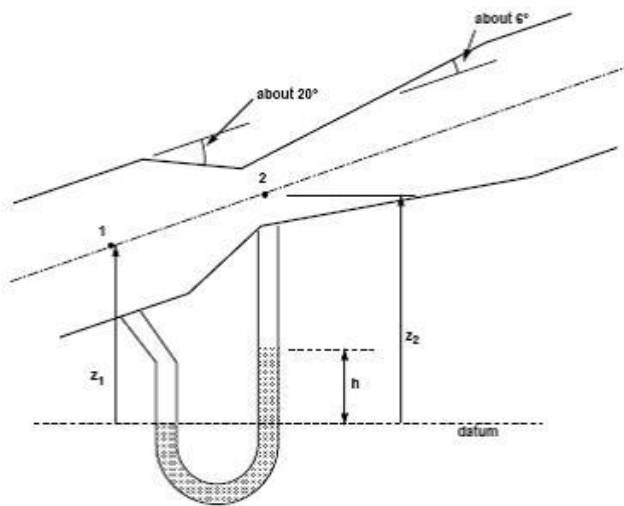

Apply Bernoulli along the streamline from point 1 to point 2

$$\frac{p_1}{\rho g} + \frac{u_1^2}{2g} + z_1 = \frac{p_2}{\rho g} + \frac{u_2^2}{2g} + z_2$$

By continuity

$$Q = u_1 A_1 = u_2 A_2$$

$$u_2 = \frac{u_1 A_1}{A_2}$$

Substituting and rearranging gives

$$\frac{p_1 - p_2}{\rho g} + z_1 - z_2 = \frac{u_1^2}{2g} \left[ \left( \frac{A_1}{A_2} \right)^2 - 1 \right]$$

$$= \frac{u_1^2}{2g} \left[ \frac{A_1^2 - A_2^2}{A_2^2} \right]$$

$$u_1 = A_2 \sqrt{\frac{2g \left[ \frac{p_1 - p_2}{\rho g} + z_1 - z_2 \right]}{A_1^2 - A_2^2}}$$

The theoretical (ideal) discharge is  $u \times A$ .

Actual discharge takes into account the losses due to friction, we include a coefficient of discharge ( $C_d \approx 0.9$ )

$$Q_{ideal} = u_1 A_1$$

$$Q_{actual} = C_d Q_{ideal} = C_d u_1 A_1$$

$$Q_{actual} = C_d A_1 A_2 \sqrt{\frac{2g \left[ \frac{p_1 - p_2}{\rho g} + z_1 - z_2 \right]}{A_1^2 - A_2^2}}$$

In terms of the manometer readings

$$p_1 + \rho g z_1 = p_2 + \rho_{man} g h + \rho g (z_2 - h)$$

$$\frac{p_1 - p_2}{\rho g} + z_1 - z_2 = h \left( \frac{\rho_{man}}{\rho} - 1 \right)$$

Giving

$$Q_{actual} = C_d A_1 A_2 \sqrt{\frac{2gh \left( \frac{\rho_{man}}{\rho} - 1 \right)}{A_1^2 - A_2^2}}$$

This expression does not include any elevation terms. ( $z_1$  or  $z_2$ ) When used with a manometer

The Venturimeter can be used without knowing its angle.

MODULE 13. LAMINAR AND TURBULENT FLOW IN PIPES

LESSON 19. FLOW IN PIPES

what is Pipe?

- A pipe is a closed conduit through which a fluid flows.
- Includes water pipes, hydraulic hoses. Circular cross section is able withstand higher pressure differentials without distortion.
- The water pipes supplying water in the house. The hypodermic needle use by heroin junkies. Pipes can be natural (veins and arteries) as well as artificial.
- Pipes can transport both liquid and gases.
- Pipe systems consists of inlets, outlets, the pipe itself, bends in the pipe, valves and pumps

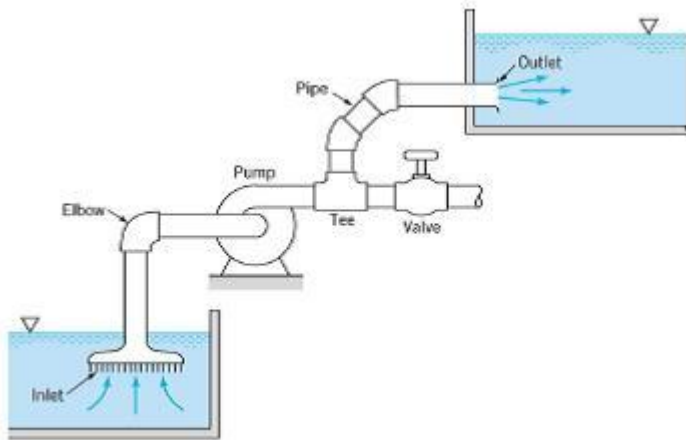

General characteristics of pipe flow

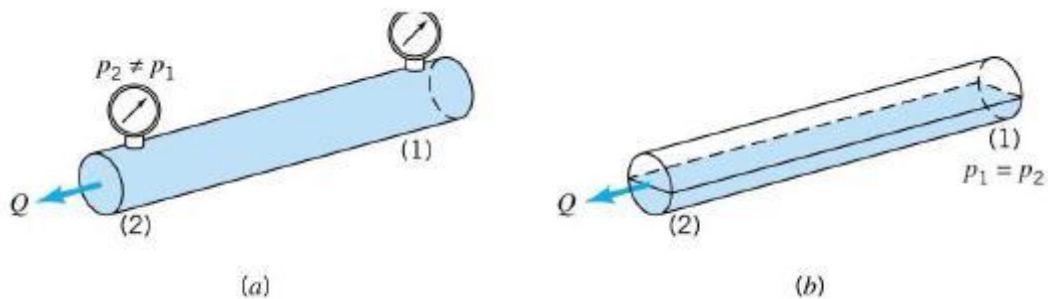

- A closed conduit is called a duct if it is square in cross section, e.g. heating and air-conditioning ducts. Lower pressure differential across wall of duct.
- The water flowing down the conduit completely fills the conduit. Storm water drains, sewers.
- If water does not fill the conduit, the flow is called channel flow. Since channel is not filled, no pressure differential between ends of pipes. Gravity is usually the driver for channel flows.

Laminar and turbulent flow

- Take a pipe of free flowing water and inject a dye into the middle of the stream, different views will be available as shown in figure below:

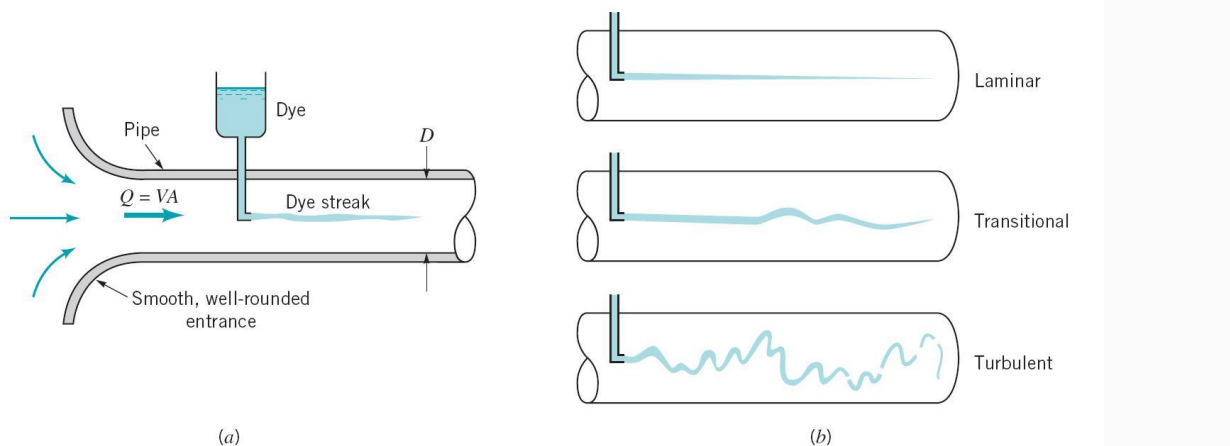

Consider a well-defined streak line, one velocity component:

$$V = u\hat{i}$$

Velocity along the pipe is unsteady and accompanied by random component normal to pipe

$$V = u\hat{i} + v\hat{j} + w\hat{k}$$

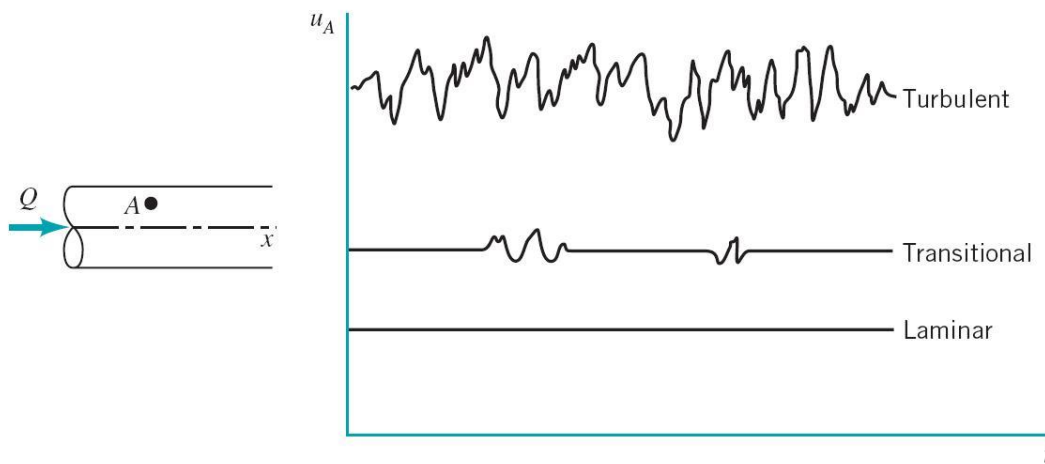

- In laminar flow the motion of the particles of fluid is very orderly with all particles moving in straight lines parallel to the pipe walls.
- The laminar flow has a constant  $u_A$  which is smallest.
- The transitional flow has a mostly constant  $u_A$  with the occasional fluctuation.
- The phenomenon was first investigated in the 1880s by Osbourne Reynolds in an experiment which has become a classic in fluid mechanics. He used a tank arranged as above with a pipe taking water from the centre into which he injected a dye through a needle. After many experiments he saw that this expression



## Fluids Mechanics

### The Reynolds number

Whether a flow will result in laminar or turbulent flow is primarily determined by the Reynolds number,

$$Re = \frac{\rho v D}{\mu}$$

Where density is  $\rho$ , diameter of pipe is  $D$ ,  $v$  is fluid velocity and  $\mu$  is viscosity.

Re values depend on shape of pipe, roughness, shape of pipe inlet. The limits are also soft numbers.

#### Laminar flow

- $Re < 2000$
- 'low' velocity
- Dye does not mix with water
- Fluid particles move in straight lines
- Simple mathematical analysis possible
- Rare in practice in water systems.

#### Transitional flow

- $2000 > Re < 4000$
- 'medium' velocity
- Dye stream wavers in water - mixes slightly.

#### Turbulent flow

- $Re > 4000$
- 'high' velocity
- Dye mixes rapidly and completely
- Particle paths completely irregular
- Average motion is in the direction of the flow
- Cannot be seen by the naked eye
- Changes/fluctuations are very difficult to detect. Must use laser.
- Mathematical analysis very difficult - so experimental measures are used
- Most common type of flow.



LESSON 20. LAMINAR AND TURBULENT FLOW

Laminar and turbulent flow

In laminar flow the streak-lines are straight lines.

The fluid flows smoothly down the pipe.

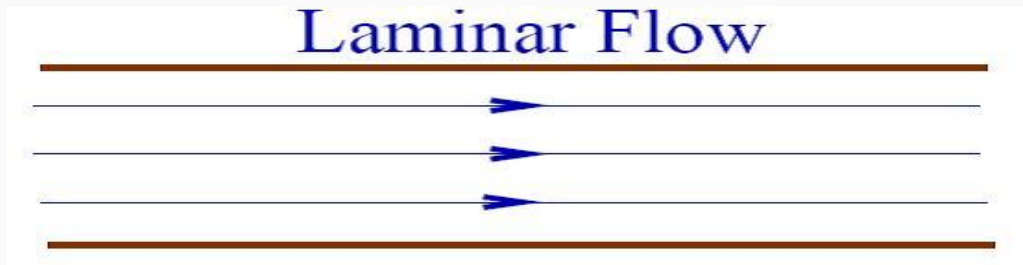

In turbulent flow the streak-lines show wiggles and vortices. The fluid does not flow smoothly down the pipe.

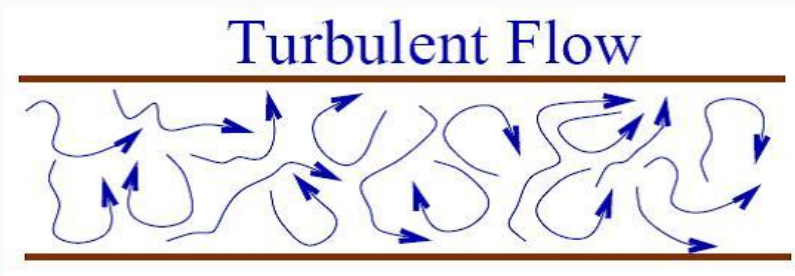

What happens when fluid enters a pipe?

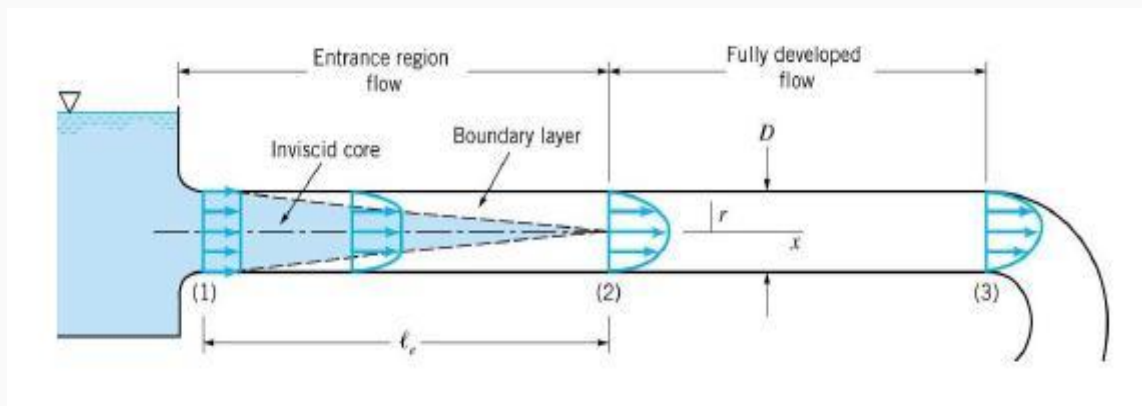

The fluid adjacent to the wall sticks to the wall due to friction effects. This is the no-slip condition and occurs for all liquids.

- This boundary layer grows until it reaches all parts of the pipe.

## Fluids Mechanics

- Inside the inviscid core, viscosity effects are not important.
- The entrance region for laminar flow is given by

$$\frac{l_e}{D} = 0.06\text{Re}$$

Past here the flow is fully developed.

### Laminar flow analysis

Assumptions, outside entrance region:

$$\frac{du}{dx} = 0$$

And steady flow. Horizontal flow

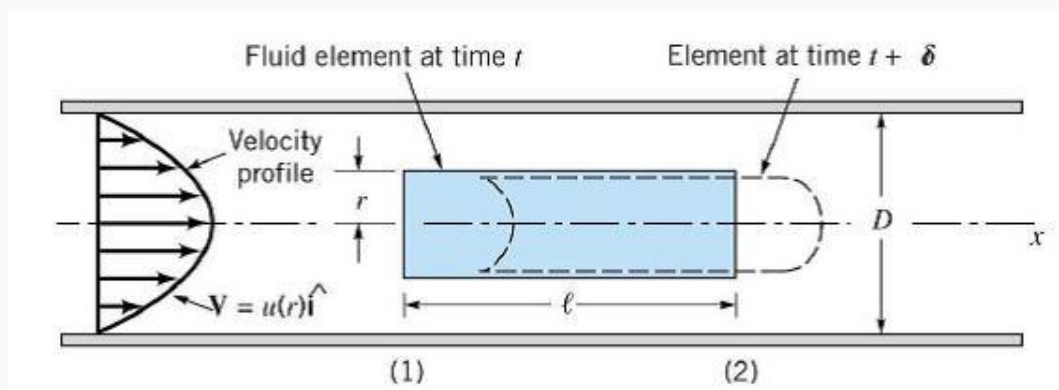

Apply  $F = ma$  to a cylinder.

The cylinder becomes distorted as  $t \rightarrow t + \partial t$

- The pressure is constant along the vertical direction.
- The pressure along horizontal direction does change.  $\Delta p = p_2 - p_1 < 0$
- There is a viscous shear stress acting along the surface cylinder and The shear stress is a function of the radius of the cylinder.

### Application of $F = ma$

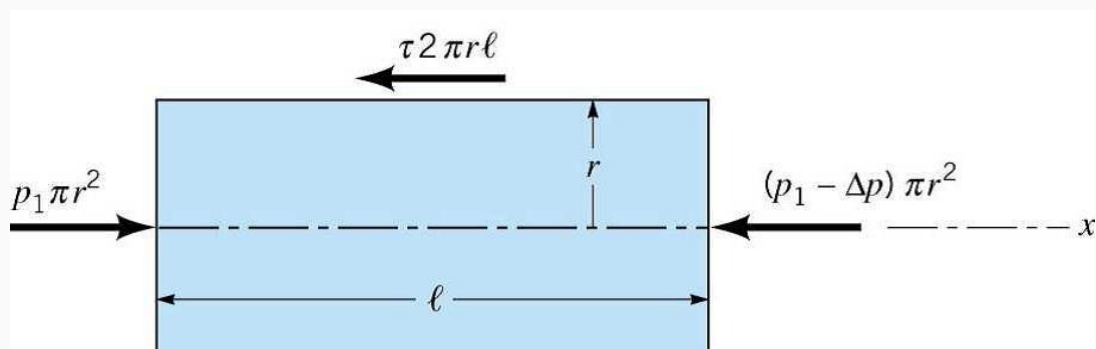

$$p_1 \pi r^2 - (p_1 - |\Delta p|) \pi r^2 = 2\pi r l \tau$$

$$\frac{\Delta p}{l} = \frac{2\tau}{r}$$

- Neither  $\Delta p$  or  $l$  depend on  $r$
- So  $\frac{\tau}{r}$  is independent of  $r$
- Then  $\tau = Cr$  where  $C$  is constant.
- At center  $r = 0$ ,  $\tau = C \times 0 = 0$ . At wall let  $\tau = \tau_w$ , where  $\tau_w$  is the wall shear stress.

$$\tau = \frac{2\tau_w r}{D}$$

$$\tau = \frac{2\tau_w r}{D}$$

$$\tau = \frac{2\tau_w r}{D}$$

If the viscosity was zero, there would be no shear stress. The shear stress also causes the pressures to drop along the pipe.

$$\Delta p = \frac{2l\tau}{r} = \frac{4l\tau_w}{D}$$

A small shear stress can result in a large pressure difference is

$$l/D \gg 1$$

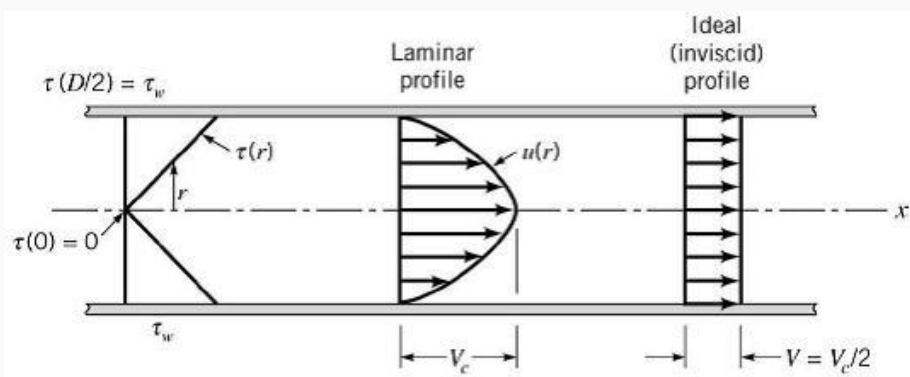

The shear stress is largest at the walls

Laminar velocity profile

To determine the laminar velocity profile, assume we have a Newtonian fluid, so

$$\tau = -\mu \frac{du}{dy}$$

$$\tau > 0 \text{ for } \frac{du}{dr} < 0$$

$$\frac{du}{dr} = -\frac{\Delta p}{2\mu l} r$$

$$u(r) = -\frac{\Delta p}{2\mu l} r^2 + u(r=0)$$

At wall  $u(r = D/2) = 0$  , so can fix  $u(r = 0) = v_c$   
and

$$u(r) = \frac{\Delta p D^2}{16\mu l} \left[ 1 - \left( \frac{2r}{D} \right)^2 \right]$$

$$u(r) = \frac{\tau_w D}{4\mu} \left[ 1 - \left( \frac{r}{R} \right)^2 \right]$$

$$u(r) = v_c \left[ 1 - \left( \frac{r}{R} \right)^2 \right]$$

$$u(r) = v_c \left[ 1 - \left( \frac{r}{R} \right)^2 \right]$$

The flow rate is parabolic, with largest velocity in middle of pipe and zero velocity at wall.

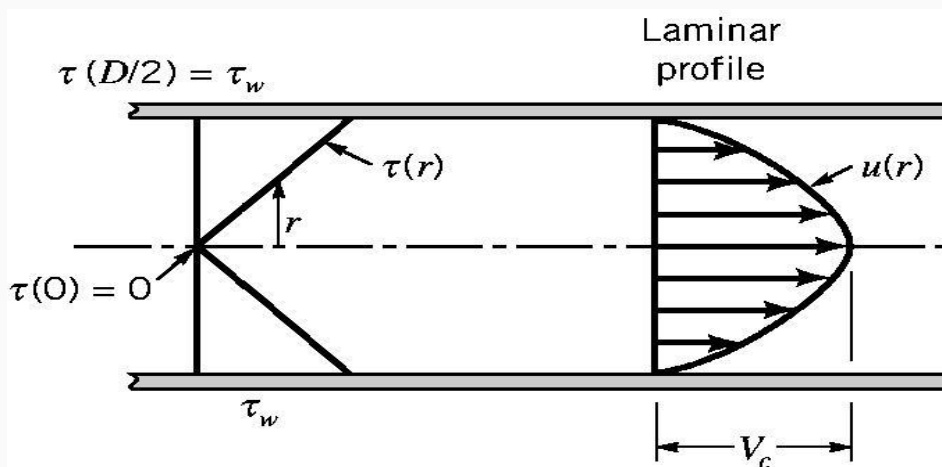

Laminar flow rate

## Fluids Mechanics

Just need to integrate the laminar velocity profile over the cross sectional area. Divide cross section into thin annular strips

$$\begin{aligned}\Delta Q &= 2\pi r \delta r u(r) \\ Q &= \int_{r=0}^{r=R} 2\pi r u(r) dr \\ &= 2\pi v_c \int_0^R r \left[1 - \frac{r^2}{R^2}\right] dr\end{aligned}$$

Now this reduces to

$$Q = \frac{\pi R^2 v_c}{2} = \frac{\pi D^4 \Delta p}{128 \mu l}$$

The mean velocity is obtained by dividing the net flow rate by the cross sectional area

$$\langle v \rangle = \frac{Q}{\pi R^2} = \frac{v_c}{2} = \frac{\Delta p D^2}{32 \mu l}$$

## Poiseuille's Law and Interpretation

The fundamental result

$$Q = \frac{\pi R^2 v_c}{2} = \frac{\pi D^4 \Delta p}{128 \mu l}$$

is usually called Poiseuille's Law. Laminar flow in pipes is sometimes termed Hagen-Poiseuille's flow.

Flow along a pipe is driven by a pressure difference.

The viscosity acts to retard the passage of the fluid along the pipe through the no-slip condition at the wall. The flow rate

- Increases when  $\Delta p$  is increased
- Decreases when  $\mu$  is increased
- Decreases when  $l$  is increased
- Increases when  $D$  is increased



### MODULE 14. GENERAL EQUATION FOR HEAD LOSS-DARCY EQUATION

#### LESSON 21. GENERAL EQUATION FOR HEAD LOSS-DARCY EQUATION

Flow of fluid through a pipe

- Head loss is the reduction in the total head or pressure (sum of elevation head, velocity head and pressure head) of the fluid as it moves through a fluid system.
- Head loss is unavoidable in real fluids. It is present because of:
  - the friction between the fluid and the walls of the pipe;
  - the friction between adjacent fluid particles as they move relative to one another; and
  - the turbulence caused whenever the flow is redirected or affected in any way by such components as piping entrances and exits, pumps, valves, flow reducers, and fittings.
- Frictional loss is that part of the total head loss that occurs as the fluid flows through straight pipes.
- The head loss for fluid flow is directly proportional to the length of pipe, the square of the fluid velocity, and a term accounting for fluid friction called the friction factor.
- The head loss is inversely proportional to the diameter of the pipe.

#### Pressure Pipe Flow

Refers to full water flow in closed conduits of circular cross sections under a certain pressure gradient. For a given discharge (Q), pipe flow at any location can be described by the pipe cross section, the pipe elevation, the pressure, and the flow velocity in the pipe.

#### Elevation (h)

of a particular section in the pipe is usually measured with respect to a horizontal reference datum such as mean sea level (MSL).

#### Pressure (P)

in the pipe varies from one point to another, but a mean value is normally used at a given cross section.

#### Mean velocity (V)

is defined as the discharge (Q) divided by the cross-sectional area (A)

$$V = \frac{Q}{A}$$

Loss of Head From Pipe Friction

Energy loss resulting from friction in a pipeline is commonly termed the **friction head loss(hf)**. This is the loss of head caused by pipe wall friction and the viscous dissipation in flowing water. It is also called **major loss**.

The most popular pipe flow equation was derived by Henry Darcy (1803 to 1858), Julius Weisbach (1806 to 1871), and the others about the middle of the nineteenth century. The equation takes the following form and is commonly known as the

Darcy-Weisbach Equation.

$$h_f = \frac{fLV^2}{2gD}$$

When Reynolds Number (NR) is less than 2000 flow in the pipe is laminar and friction factor is calculated with the following formula;

$$f = \frac{64}{Nr}$$

When Reynolds Number (NR) is greater or equal to 2000, the flow in the pipe becomes practically turbulent and the value of friction factor (f) then becomes less dependent on the Reynolds Number but more dependent on the **relative roughness** (e/D) of the pipe. The roughness height for certain common commercial pipe materials is provided in Table 1.1.

**Table 1.1 Roughness Heights ,e, for Certain Common Materials**

Pipe Material	e (mm)	e (ft)
Brass	0.0015	0.000005
Concrete		
Steel forms, smooth	0.18	0.0006
Good joints, average	0.36	0.0012
Rough, visible form marks	0.60	0.002
Copper	0.0015	0.000005
Corrugated metal (CMP)	45	0.15
Iron (common in older water lines, except ductile or DIP, which is widely used today)		
Asphalt lined	0.12	0.0004
Cast	0.26	0.00085
Ductile; DIP—cement mortar lined	0.12	0.0004
Galvanized	0.15	0.0005
Wrought	0.045	0.00015
Polyvinyl chloride (PVC)	0.0015	0.000005
Polyethylene, high density (HDPE)	0.0015	0.000005
Steel		
Enamel coated	0.0048	0.000016
Riveted	0.9 ~ 9.0	0.003–0.03
Seamless	0.004	0.000013
Commercial	0.045	0.00015



Friction factor can be found in three ways:

1. Graphical solution: Moody Diagram
2. Implicit equations : Colebrook-White Equation
3. Explicit equations: : Swamee-Jain Equation

**1. Graphical solution: Moody Diagram**

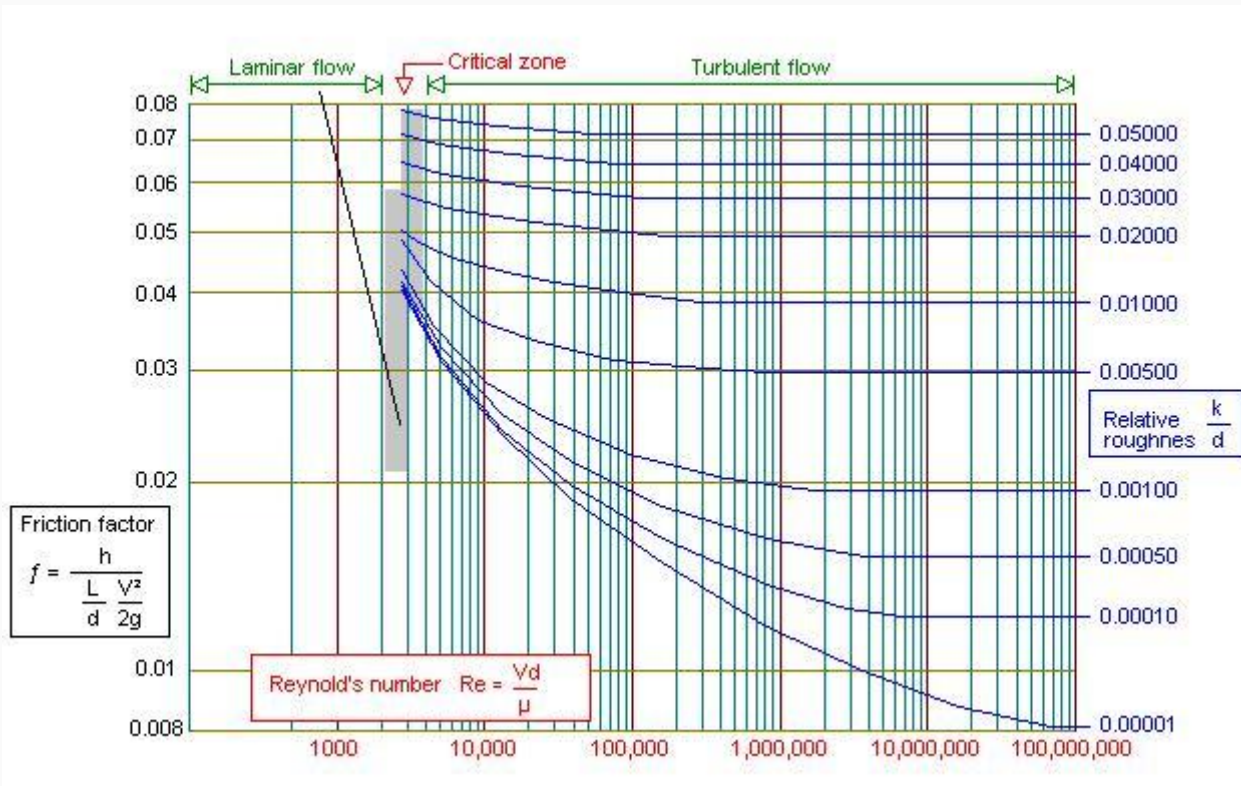

**2. Implicit equations : Colebrook-White Equation**

$$\frac{1}{\sqrt{f}} = -\log \left( \frac{e/D}{3.7} + \frac{2.51}{N_R \sqrt{f}} \right)$$

**3. Explicit equations : Swamee-Jain Equation**

$$f = \frac{0.25}{\left[ \log \left( \frac{e/D}{3.7} + \frac{5.74}{N_R^{0.9}} \right) \right]^2}$$



## LESSON 22. EMPIRICAL EQUATIONS FOR FRICTION HEAD LOSS

### Hazen-Williams equation:

It was developed for water flow in larger pipes ( $D \geq 5$  cm, approximately 2 in.) within a moderate range of water velocity ( $V \leq 3$  m/s, approximately 10 ft/s). Hazen-Williams equation, originally developed for the British measurement system, has been written in the form

$$V = 1.318 C_{HW} R_h^{0.63} S^{0.54}$$

$S$  = slope of the energy grade line, or the head loss per unit length of the pipe ( $S = hf/L$ )

$R_h$  = the hydraulic radius, defined as the water cross sectional area ( $A$ ) divided by wetted perimeter ( $P$ ). For a circular pipe, with  $A = \pi D^2/4$  and  $P = \pi D$ , the hydraulic radius is

$$R_h = \frac{A}{P} = \frac{\pi D^2/4}{\pi D} = \frac{D}{4}$$

$C_{HW}$  = Hazen-Williams coefficient. The values of  $C_{HW}$  for commonly used water-carrying conduits are given in Table 1.2.

The Hazen-Williams equation in SI units is written in the form of

$$V = 0.849 C_{HW} R_h^{0.63} S^{0.54}$$

Velocity in m/s and  $R_h$  is in meters

Table 1.2. Hazen-Williams coefficient for different type of pipes

Pipe Materials	$C_{HW}$
Brass	130–140
Cast iron (common in older water lines)	
New, unlined	130
10-year-old	107–113
20-year-old	89–100
30-year-old	75–90
40-year-old	64–83
Concrete or concrete lined	
Smooth	140
Average	120
Rough	100
Copper	130–140
Ductile iron (cement mortar lined)	140
Glass	140
High-density polyethylene (HDPE)	150
Plastic	130–150
Polyvinyl chloride (PVC)	150
Steel	
Commercial	140–150
Riveted	90–110
Welded (seamless)	100
Vitrified clay	110

### Manning’s Equation

Manning equation has been used extensively open channel designs. It is also quite commonly used for pipe flows. The Manning equation may be expressed in the following form:

$$V = \frac{1}{n} R_h^{2/3} S^{1/2}$$

n= Manning’s coefficient of roughness. Typical values of n for water flow in common pipe materials is given in Table 1.3

In British units, the Manning equation is written as

$$V = \frac{1.486}{n} R_h^{2/3} S^{1/2}$$

Where V is units of ft/s.

Table 1.3. Manning Roughness Coefficient for pipe flows

Type of Pipe	Manning's $n$	
	Min.	Max.
Brass	0.009	0.013
Cast iron	0.011	0.015
Cement mortar surfaces	0.011	0.015
Cement rubble surfaces	0.017	0.030
Clay drainage tile	0.011	0.017
Concrete, precast	0.011	0.015
Copper	0.009	0.013
Corrugated metal (CMP)	0.020	0.024
Ductile iron (cement mortar lined)	0.011	0.013
Glass	0.009	0.013
High-density polyethylene (HDPE)	0.009	0.011
Polyvinyl chloride (PVC)	0.009	0.011
Steel, commercial	0.010	0.012
Steel, riveted	0.017	0.020
Vitrified sewer pipe	0.010	0.017
Wrought iron	0.012	0.017



MODULE 15. MAJOR AND MINOR HYDRAULIC LOSSES THROUGH PIPES AND FITTING

LESSON 23. MAJOR AND MINOR HYDRAULIC LOSSES THROUGH PIPES AND FITTING

LOSSES IN PIPE FLOW

- The flow through most pipes is turbulent. Treatment with classical analytic techniques next to impossible. Available techniques are basic on experimental data and empirical formulae. The working equations are often derived from dimensional analysis using dimensionless forms. Often desirable to determine the head loss,  $h_L$  so that the energy equation can be used. Pipe systems come with valves, bends, pipe diameter changes, elbows which also contribute to the energy (head) loss.
- The overall head loss is divided into two parts major loss  $h_{Lmajor}$  , and minor loss  $h_{Lminor}$  . The major loss comes from viscosity (in straight pipe) while the minor loss is due to energy loss in the components.
- The major loss can actually be smaller than the minor loss for a pipe system containing short pipes and many bends and valves.
- When a fluid flows through a pipe, there is some resistance to fluid due to which fluid loses its energy. This loss of energy can be classified in to following types.

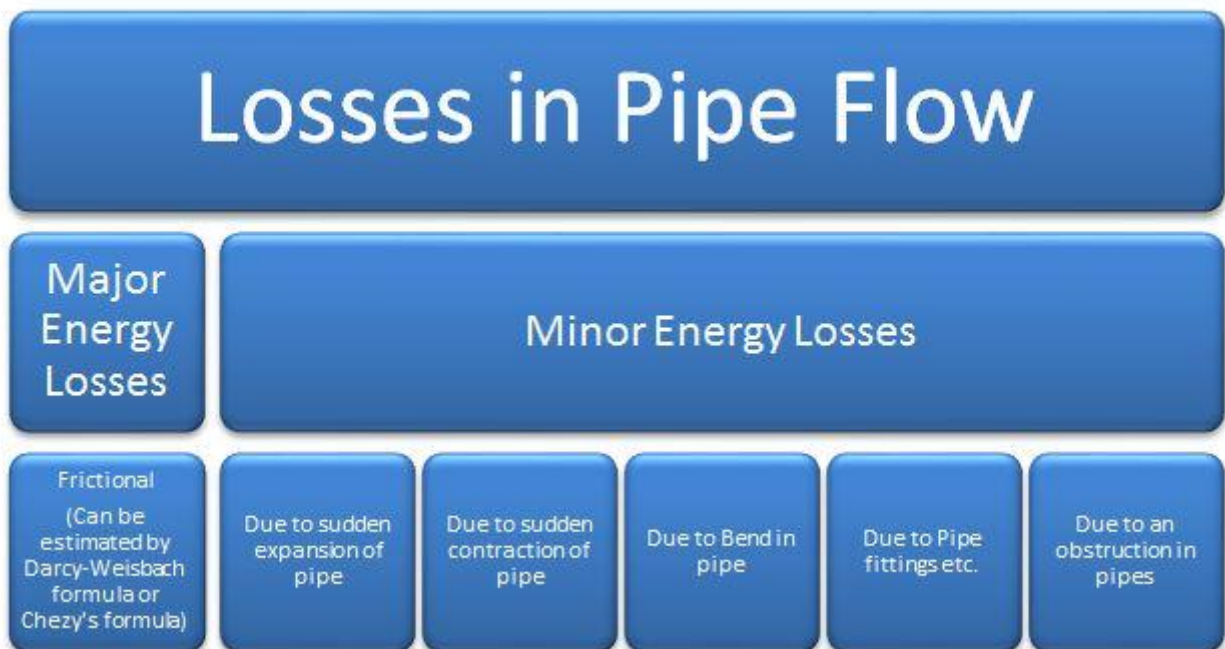

- It is often necessary to determine the head loss,  $h_L$ , that occur in a pipe flow so that the energy equation, can be used in the analysis of pipe flow problems.
- The overall head loss for the pipe system consists of the head loss due to viscous effects in the straight pipes, termed the major loss and denoted  $h_{L-major}$ .

## Fluids Mechanics

- The head loss in various pipe components, termed the minor loss and denoted  $h_{L-minor}$ .

$$h_L = h_{L-major} + h_{L-minor}$$

For a pipe system that contains many components and a relatively short length of pipe, the minor loss may actually be larger than the major loss.

### Major Losses

- Darcy-Weisbach formula
- The head loss,  $h_{L-major}$  is given as ;

$$h_{L-major} = f \frac{\ell V^2}{D 2g}$$

where  $f$  is friction factor.

- It is valid for any fully developed, steady, incompressible pipe flow, whether the pipe is horizontal or on hill.

Friction factor for laminar flow is

$$f = \frac{64}{\text{Re}}$$

- Friction factor for turbulent flow is based on *Moody* chart.

It is because, in turbulent flow, Reynolds number and relative roughness influence the friction.

- Reynolds number is given by following,

$$\text{Re} = \frac{\rho V D}{\mu}$$

$$\text{Relative roughness} = \frac{\varepsilon}{D}$$

(relative roughness is not present in the laminar flow)

The pressure loss in a pipe for turbulent flow:

- Depends on the following
- $\rho$
- $\mu$ 
  - $v$ ,  $l$  and  $D$
  - Surface roughness  $\varepsilon$ .

These projections of the wall can and protrude out of the laminar sub-layer.

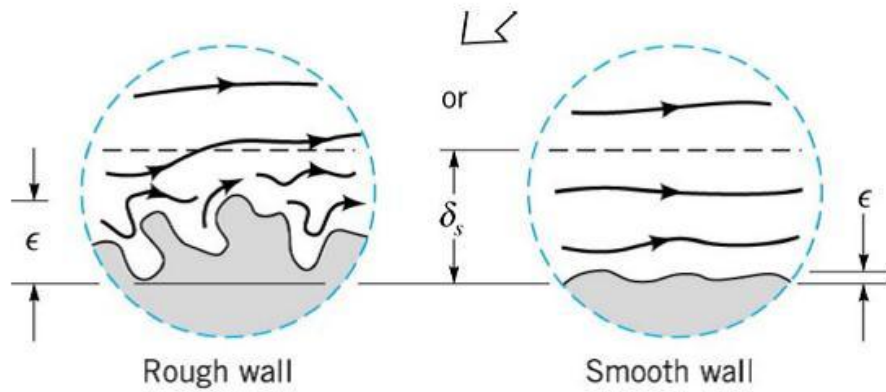

Viscous flows in pipes

**Generalized one-dimensional Bernoulli equation for viscous flow.**

When the viscosity of the fluid is taken into account total energy head

$$H = \frac{v^2}{2g} + \frac{p}{\rho g} + z$$

Is no longer constant along the pipe. In direction of flow, due to friction cause by viscosity of the fluid we have

$$\frac{v_1^2}{2g} + \frac{p_1}{\rho g} + z_1 > \frac{v_2^2}{2g} + \frac{p_2}{\rho g} + z_2.$$

So to restore the equality we must add some scalar quantity to the right side of this inequality

$$\frac{v_1^2}{2g} + \frac{p_1}{\rho g} + z_1 = \frac{v_2^2}{2g} + \frac{p_2}{\rho g} + z_2 + \Delta h_{ls}$$

This scalar quantity  $\Delta h_{ls}$  is called as hydraulic loss. The hydraulic loss between two different cross section along the pipe is equal to the difference of total energy for this cross section:

$$\Delta h_{ls} = H_1 - H_2$$

We must remember that always  $H_1 > H_2$ . In horizontal pipe when  $z_1 = z_2$  and diameter of pipe is constant  $v_1 = v_2$  hydraulic loss is equal to the head of pressure drop or *head loss*

$$\Delta h_L = \frac{p_1 - p_2}{\rho g}$$

Head loss is express by Darcy -Weisbach equation:

$$h_L = f \frac{L}{D} \frac{v^2}{2g}$$

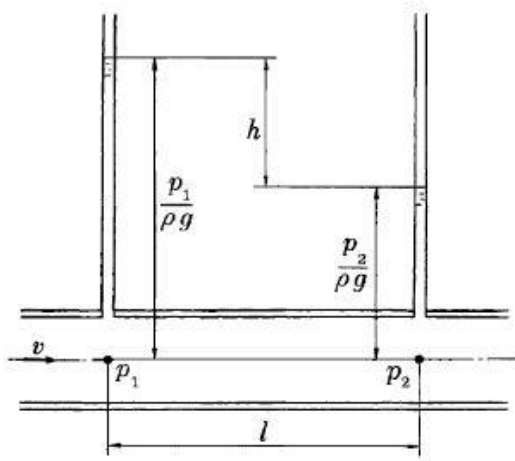

Figure 1: Pipe friction loss. For horizontal pipe, with constant diameter this loss may be measured by height of the pressure drop:  $\Delta p/\rho g = h$

We must remember that equation (4) is valid only for horizontal pipes. In general, with  $v_1 = v_2$

but  $z_1 \neq z_2$ , the head loss is given

$$\frac{p_1 - p_2}{\rho g} = (z_2 - z_1) + f \frac{L}{D} \frac{v^2}{2g}$$

Part of the pressure change is due to elevation change and part is due to head loss associated with frictional effects, which are given in terms of the *friction factor*  $f$  that depends on Reynolds number and relative roughness

$$f = \varphi(Re, \varepsilon/D)$$





### MODULE 16. DIMENSIONAL ANALYSIS AND SIMILITUDE

#### LESSON 24. DIMENSIONAL ANALYSIS

##### Dimensions

- Engineering deals with definite and measured quantities, and so depends on the making of measurements. We must be clear and precise in making these measurements.
- Engineering entities can be expressed in terms of relatively small number of dimensions.
- These are length, mass, time and temperature.
- Application of fluid mechanics in design makes use of experiments results.
- Results often difficult to interpret.
- Dimensional analysis provides a strategy for choosing relevant data.
- Used to help analyze fluid flow. Especially when fluid flow is too complex for mathematical analysis.

The area where dimensional analysis is used are:

- design experiments
- Informs which measurements are important
- Allows most to be obtained from experiment:

e.g. What runs to do. How to interpret.

- It depends on the correct identification of variables
- Relates these variables together
- Doesn't give the complete answer
- Experiments necessary to complete solution
- Uses principle of dimensional homogeneity
- Give qualitative results which only become quantitative from experimental analysis.

##### Dimensions and units

- Any physical situation can be described by familiar properties.

e.g. length, velocity, area, volume, acceleration etc.

- These are all known as dimensions.

## Fluids Mechanics

- Dimensions are of no use without a magnitude.

i.e. a standardised unit e.g metre, kilometre, Kilogram, a yard etc.

- Dimensions can be measured.
- Units used to quantify these dimensions.
- In dimensional analysis we are concerned with the nature of the dimension i.e. its quality not its quantity.

The following common abbreviations are used:

Length [L]

Area [L<sup>2</sup>]

Mass [M]

Time [θ]

Force [F]

Temperature [T]

- Here we will use L, M, T and F.
- We can represent all the physical properties we are interested in with three:

L, T and one of M or F

- As either mass (M) or force (F) can be used to represent the other, i.e.

$$F = MLT^{-2}$$

$$M = FT^2L^{-1}$$

- We will always use LTM:
- This table lists dimensions of some common physical quantities:

Quantity	SI Unit		Dimension
velocity	m/s	ms <sup>-1</sup>	LT <sup>-1</sup>
acceleration	m/s <sup>2</sup>	ms <sup>-2</sup>	LT <sup>-2</sup>
force	N kg m/s <sup>2</sup>	kg ms <sup>-2</sup>	MLT <sup>-2</sup>
energy (or work)	Joule J N m, kg m <sup>2</sup> /s <sup>2</sup>	kg m <sup>2</sup> s <sup>-2</sup>	ML <sup>2</sup> T <sup>-2</sup>
power	Watt W N m/s kg m <sup>2</sup> /s <sup>3</sup>	Nms <sup>-1</sup> kg m <sup>2</sup> s <sup>-3</sup>	ML <sup>2</sup> T <sup>-3</sup>
pressure ( or stress)	Pascal P, N/m <sup>2</sup> , kg/m/s <sup>2</sup>	Nm <sup>-2</sup> kg m <sup>-1</sup> s <sup>-2</sup>	ML <sup>-1</sup> T <sup>-2</sup>
density	kg/m <sup>3</sup>	kg m <sup>-3</sup>	ML <sup>-3</sup>
specific weight	N/m <sup>3</sup> kg/m <sup>2</sup> /s <sup>2</sup>	kg m <sup>-2</sup> s <sup>-2</sup>	ML <sup>-2</sup> T <sup>-2</sup>
relative density	a ratio no units		1 no dimension
viscosity	N s/m <sup>2</sup> kg/m s	N sm <sup>-2</sup> kg m <sup>-1</sup> s <sup>-1</sup>	ML <sup>-1</sup> T <sup>-1</sup>
surface tension	N/m kg /s <sup>2</sup>	Nm <sup>-1</sup> kg s <sup>-2</sup>	MT <sup>-2</sup>

### The buckingham pi theorem

The buckingham pi theorem puts the ‘method of dimensions’ first proposed by lord rayleigh in his book “*the theory of sound*” (1877) on a solid theoretical basis, and is based on ideas of matrix algebra and concept of the ‘rank’ of non-square matrices which you may see in math classes. although it is credited to E. Buckingham (1914), in fact, white points out that the theorem has also appeared earlier in independent publications by a. vaschy (1892) and d. riabouchinsky (1911).

#### The Theorem

Let  $q_1, q_2, q_3, \dots, q_n$  be  $n$  dimensional variables that are physically relevant in a given problem and that are interrelated by an unknown dimensionally homogeneous set of equations. These can be expressed via a functional relationship of the form:

$$F(q_1, q_2, \dots, q_n) = 0$$

$$q_1 = f(q_2, \dots, q_n)$$

If  $k$  is the number of fundamental dimensions required to describe the  $n$  variables, then there will be  $k$  primary variables and the remaining  $j = (n - k)$  variables can be expressed as  $(n - k)$  dimensionless and independent quantities or pi groups  $\Pi_1, \Pi_2, \dots, \Pi_{n-k}$ . The functional relationship can thus be reduced to the much more compact form:

$$\phi(\Pi_1, \Pi_2, \dots, \Pi_{n-k}) = 0 \quad \text{or equivalently} \quad \Pi_1 = \phi(\Pi_2, \dots, \Pi_{n-k}).$$

### Applications of Buckingham pi Theorem

i) Clearly define the problem and think about which variables are important. Identify which is the main variable of interest i.e.  $q_1=f(q_2\dots q_n)$ . It is important to think physically about the problem. Are there any constraints; i.e. 'can I vary all of these variables independently';

e.g. weight of an object  $F_w=\rho g l^3$  (only two of these are independent, unless  $g$  is also variable)

ii) Express each of  $n$  variable in terms of its fundamental dimensions,  $\{MLT\theta\}$  or  $\{FLT\theta\}$  It is often useful to use one system to do problem, and then check that groups you obtain are dimensionless by converting to other system.

iii) Determine the number of Pi groups  $j=n-k$ , where  $k$  is the number of reference dimensions and select  $k$  primary or repeating variables. Typically pick variables which characterize the fluid properties, flow geometry, flow rate...

iv) Form  $j$  dimensionless  $\Pi$  groups and check that they are all indeed dimensionless.

v) Express result in form  $\Pi_1= \phi_1(\Pi_2,\dots \Pi_{n-k})$  where  $\Pi_1$  contains the quantity of interest and interpret your result physically!

vi) Make sure that your groups are indeed independent; i.e. can I vary one and keep others constant.

vii) Compare with experimental data!



## LESSON 25. DIMENSIONAL HOMOGENEITY

### Dimensional Homogeneity

- Any equation is only true if both sides have the same dimensions.
- It must be dimensionally homogenous.

What are the dimensions of  $X$ ?

$$\frac{2}{3} B \sqrt{2gH}^{3/2} = X$$

$$L (LT^{-2})^{1/2} L^{3/2} = X$$

$$L (L^{1/2} T^{-1}) L^{3/2} = X$$

$$L^3 T^{-1} = X$$

- The powers of the individual dimensions must be equal on both sides.

(for L they are both 3, for T both -1).

- Dimensional homogeneity can be useful for:

1. Checking units of equations;
2. Converting between two sets of units;
3. Defining dimensionless relationships

- What exactly do we get from Dimensional Analysis?  
A single equation, which relates all the physical factors of a problem to each other.

An example:

Problem: What is the force,  $F$ , on a propeller?

What might influence the force?

It would be reasonable to assume that the force,  $F$ , depends on the following physical properties?

Diameter,  $d$

Forward velocity of the propeller (velocity of the plane),  $u$

Fluid density,  $\rho$

Revolutions per second,  $N$

Fluid viscosity,  $\mu$

From this list we can write this equation:

## Fluids Mechanics

$$F = \phi(d, u, \rho, N, \mu)$$

or

$$0 = \phi_i(F, d, u, \rho, N, \mu)$$

$\phi$  and  $\phi_i$  are unknown functions.

Dimensional Analysis produces:

$$\phi\left(\frac{F}{\rho u^2 d^2}, \frac{Nd}{u}, \frac{\mu}{\rho u d}\right) = 0$$

These groups are dimensionless.

$\emptyset$  will be determined by experiment.

These dimensionless groups help to decide what experimental measurements to take.

These groups are *dimensionless*.

$\emptyset$  will be determined by experiment.

These dimensionless groups help to decide what experimental measurements to take.

Several groups will appear again and again.

These often have names.

They can be related to physical forces.

Other common non-dimensional numbers or ( $\pi$  groups):

**Reynolds number:**

$$Re = \frac{\rho u d}{\mu} \quad \text{inertial, viscous force ratio}$$

**Euler number:**

$$En = \frac{P}{\rho u^2} \quad \text{pressure, inertial force ratio}$$

**Froude number:**

$$Fn = \frac{u^2}{gd} \quad \text{inertial, gravitational force ratio}$$

**Weber number:**

$$We = \frac{\rho u d}{\sigma} \quad \text{inertial, surface tension force ratio}$$

**Mach number:**

$$Mn = \frac{u}{c} \quad \text{Local velocity, local velocity of sound ratio}$$

## Similarity

## Fluids Mechanics

Similarity is concerned with how to transfer measurements from models to the full scale.

Three types of similarity which exist between a model and prototype:

Geometric similarity:

The ratio of all corresponding dimensions

in the model and prototype are equal.

**For lengths**

$$\frac{L_{\text{model}}}{L_{\text{prototype}}} = \frac{L_m}{L_p} = \lambda_L$$

$\lambda_L$  is the scale factor for length.

**For areas**

$$\frac{A_{\text{model}}}{A_{\text{prototype}}} = \frac{L_m^2}{L_p^2} = \lambda_L^2$$

All corresponding angles are the same.

Kinematic similarity :

The similarity of time as well as geometry.

It exists if:

- i. the paths of particles are geometrically similar
- ii. the ratios of the velocities of are similar

Some useful ratios are:

**Velocity**  $\frac{V_m}{V_p} = \frac{L_m / T_m}{L_p / T_p} = \frac{\lambda_L}{\lambda_T} = \lambda_v$

**Acceleration**  $\frac{a_m}{a_p} = \frac{L_m / T_m^2}{L_p / T_p^2} = \frac{\lambda_L}{\lambda_T^2} = \lambda_a$

**Discharge**  $\frac{Q_m}{Q_p} = \frac{L_m^3 / T_m}{L_p^3 / T_p} = \frac{\lambda_L^3}{\lambda_T} = \lambda_Q$

A consequence is that streamline patterns are the same.

**Dynamic similarity**

If geometrically and kinematically similar and the ratios of all forces are the same.

**Force ratio**

$$\frac{F_m}{F_p} = \frac{M_m a_m}{M_p a_p} = \frac{\rho_m L_m^3}{\rho_p L_p^3} \times \frac{\lambda_L}{\lambda_T^2} = \lambda_\rho \lambda_L^2 \left(\frac{\lambda_L}{\lambda_T}\right)^2 = \lambda_\rho \lambda_L^2 \lambda_u^2$$

This occurs when the controlling  $\pi$  group is the same for model and prototype.

The controlling  $\pi$  group is usually Re. So Re is the same for model and prototype:

$$\frac{\rho_m u_m d_m}{\mu_m} = \frac{\rho_p u_p d_p}{\mu_p}$$

It is possible another group is dominant.

In open channel i.e. river Froude number is often taken as dominant.

**Modelling and Scaling Laws**

Measurements taken from a model needs a scaling law applied to predict the values in the prototype

An example:

For resistance  $R$ , of a body moving through a fluid.

$R$ , is dependent on the following:

$$\rho: ML^{-3} \quad u: LT^{-1} \quad l:(length)L \quad \mu: ML^{-1}T^{-1}$$

So

$$\phi(R, \rho, u, l, \mu) = 0$$

Taking  $\rho, u, l$  as repeating variables gives:

$$\frac{R}{\rho u^2 l^2} = \phi\left(\frac{\rho u l}{\mu}\right)$$

$$R = \rho u^2 l^2 \phi\left(\frac{\rho u l}{\mu}\right)$$

This applies whatever the size of the body i.e. it is applicable to prototype and a geometrically similar model.

For the model

$$\frac{R_m}{\rho_m u_m^2 l_m^2} = \phi\left(\frac{\rho_m u_m l_m}{\mu_m}\right)$$

and for the prototype



$$\frac{R_p}{\rho_p u_p^2 l_p^2} = \phi\left(\frac{\rho_p u_p l_p}{\mu_p}\right)$$

Dividing these two equations gives

$$\frac{R_m / \rho_m u_m^2 l_m^2}{R_p / \rho_p u_p^2 l_p^2} = \frac{\phi(\rho_m u_m l_m / \mu_m)}{\phi(\rho_p u_p l_p / \mu_p)}$$

We can go no further without some assumptions.

Assuming dynamic similarity, so Reynolds number are the same for both the model and prototype:

$$\frac{\rho_m u_m d_m}{\mu_m} = \frac{\rho_p u_p d_p}{\mu_p}$$

so

$$\frac{R_m}{R_p} = \frac{\rho_m u_m^2 l_m^2}{\rho_p u_p^2 l_p^2}$$

i.e. a scaling law for resistance force:

$$\lambda_R = \lambda_\rho \lambda_u^2 \lambda_L^2$$



### MODULE 17. INTRODUCTION TO FLUID MACHINERY

#### LESSON 26. INTRODUCTION TO FLUID MACHINERY

##### What is Fluid machine?

- A fluid machine is a device which converts the energy stored by a fluid into mechanical energy or *vice versa*. The energy stored by a fluid mass appears in the form of potential, kinetic and intermolecular energy. The mechanical energy, on the other hand, is usually transmitted by a rotating shaft.
- Machines using liquid (mainly water, for almost all practical purposes) are termed as hydraulic machines.
- The fluid machines use either liquid or gas as the working fluid depending upon the purpose.
- The machine transferring mechanical energy of rotor to the energy of fluid is termed as a pump when it uses liquid, and is termed as a compressor or a fan or a blower, when it uses gas.
- The compressor is a machine where the main objective is to increase the static pressure of a gas. Therefore, the mechanical energy held by the fluid is mainly in the form of pressure energy.
- Fans or blowers, on the other hand, mainly cause a high flow of gas, and hence utilize the mechanical energy of the rotor to increase mostly the kinetic energy of the fluid.
- In these machines, the change in static pressure is quite small.
- For all practical purposes, liquid used by the turbines producing power is water, and therefore, they are termed as *water turbines* or *hydraulic turbines*. Turbines handling gases in practical fields are usually referred to as steam turbine, gas turbine, and air turbine depending upon whether they use steam, gas (the mixture of air and products of burnt fuel in air) or air.

Fluid machine may be divided into two groups;

##### A) Positive displacement

piston pump

peristaltic pump

gear pump

two-lobe rotary pump

screw pump

Jet pumps

## Fluids Mechanics

### B) Turbomachines

axial-flow (propeller pump)

radial-flow (centrifugal pump)

mixed-flow (both axial and radial flow)

### Positive displacement machines

- can produce very high pressures
- hydraulic fluid pump
- high pressure water washers

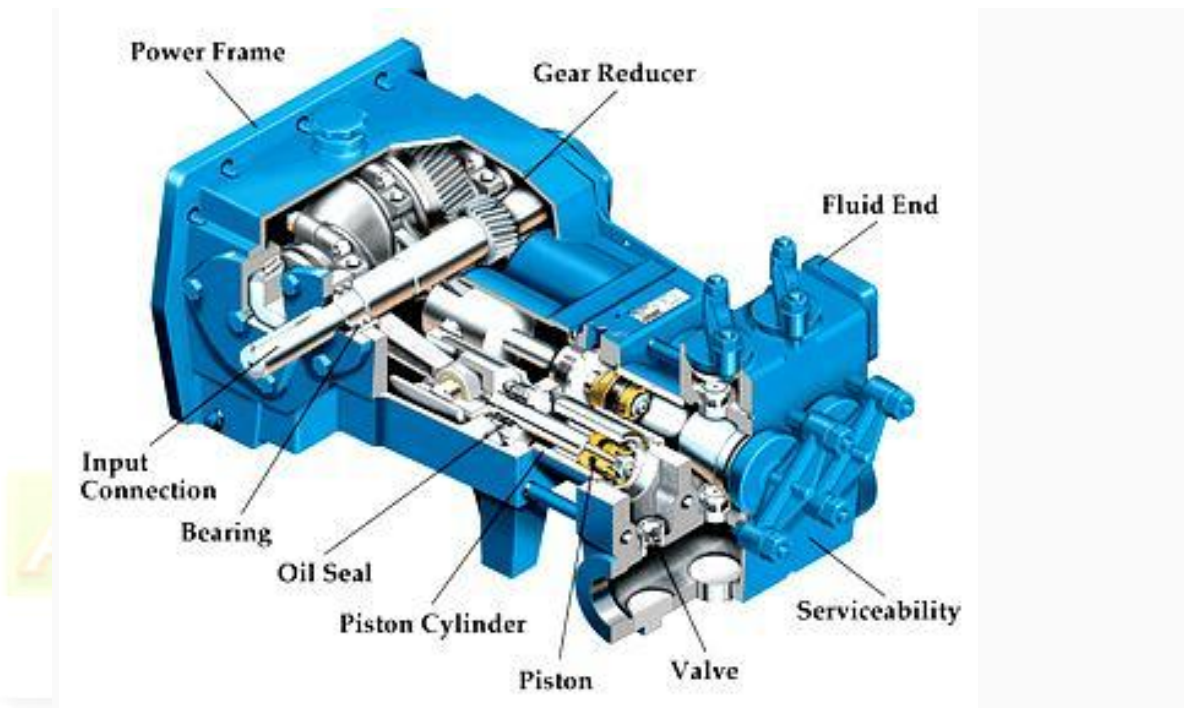

### Peristaltic Pump

- Fluid only contacts tubing
- Tubing ID and roller velocity with respect to the tubing determine flow rate
- Tubing eventually fails from fatigue and abrasion
- Fluid may leak past roller at high pressures
- Viscous fluids may be pumped more slowly

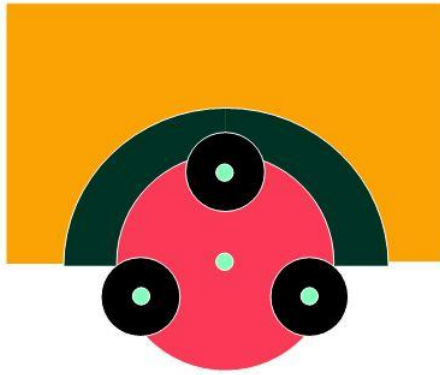

Rotary Pumps

- Gear Pump
- fluid is trapped between gear teeth and the housing
- Two-lobe Rotary Pump
- (gear pump with two "teeth" on each gear)
- same principle as gear pump
- fewer chambers - more extreme pulsation

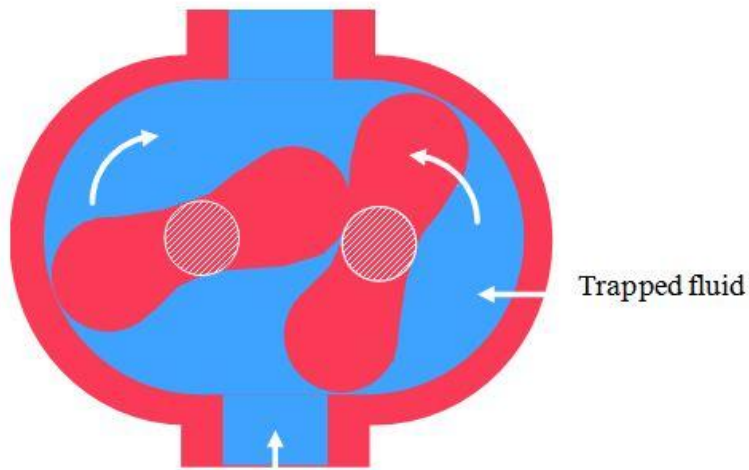

Screw Pump

- Can handle debris
- Used to raise the level of wastewater
- Abrasive material will damage the seal between screw and the housing
- Grain augers use the same principle

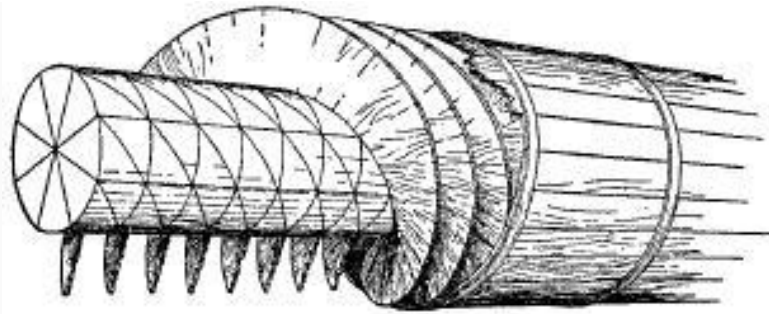

**Rotodynamic machines (Turbomachines)**

- All rotodynamic machines have a rotating component through which the fluid passes. In a turbine this is called the rotor which has a number of vanes or blades.
- The fluid passes through the blades and drives the rotor round transferring tangential momentum to the rotor
- Rotodynamic machines are smooth and continuous in action with a consequent pulsation free flow from pumps and smooth rotation from turbines. In the event of pump discharge flow being suddenly stopped there are no high shock loads. Positive displacement machines can easily be damaged if a discharge valve is suddenly closed. Rotodynamic pumps are ideal for high flow low discharge head duties and provide compact reliable solutions.
- Some of the important rotodynamic machines are as below:

### Radial Pumps (centrifugal pump)

- also called centrifugal pumps
- broad range of applicable flows and heads
- higher heads can be achieved by increasing the diameter or the rotational speed of the impeller

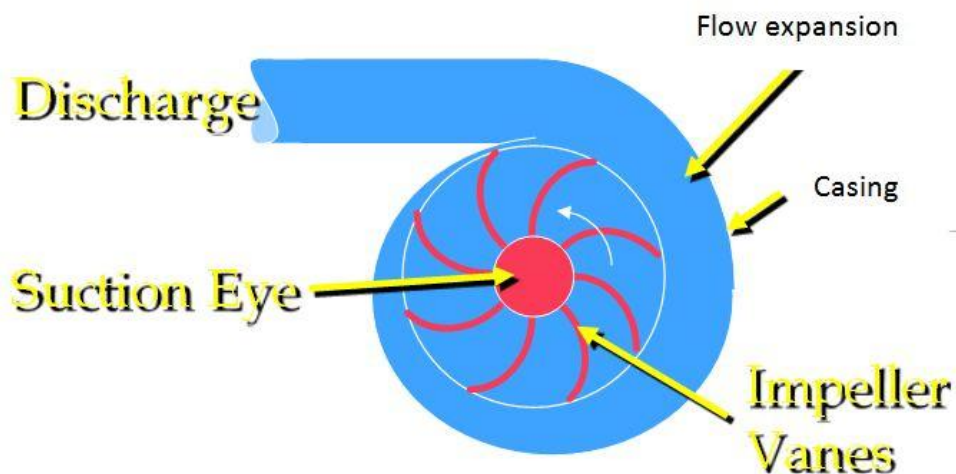

**Axial Flow**

## Fluids Mechanics

- also known as propeller pumps
- low head (less than 12 m)
- high flows (above 20 L/s)



### • Turbines and pumps

A turbine directly converts fluid energy into rotating shaft energy.

If the fluid motion is converted, initially to reciprocating mechanical motion the machine is an engine e.g and internal combustion engine or a steam engine ).

A machine for converting mechanical energy into fluid flow is called a pump...

#### Compressors or Fan

If the machine converts mechanical energy to increase the potential energy of a compressible fluid by increasing its pressure the machine is called a compressor. If the machine is primarily provided to increase the kinetic energy of a compressible fluid e.g. air, the machine is a fan. With a fan or blower the pressure head developed is usually relatively small and fluid calculations can often be done assuming the fluid is incompressible.

#### Positive Displacement Machines

A pump can be a positive displacement machine or a rotodynamic machine Ref. Pumps Positive displacement machines are designed such that there is virtually zero fluid slippage in the energy transfer process. The general principle of these type of pumps is that fluid is drawn into a chamber at a low pressure. The inlet to the chamber is closed and the outlet is opened, and the fluid is then forced out of the chamber by reducing its volume.

The type of pump can be used to generate very high pressures in a compact mechanical envelope. The main disadvantage is that the operation is an intermittent one resulting in a high level of pressure fluctuation throughout the operating cycle.



\*\*\*\*\* 😊 \*\*\*\*\*

This Book Download From e-course of ICAR  
**Visit for Other Agriculture books, News,  
Recruitment, Information, and Events at**  
**[WWW.AGRIMOON.COM](http://WWW.AGRIMOON.COM)**

Give FeedBack & Suggestion at [info@agrmoon.com](mailto:info@agrmoon.com)

**Send a Massage for daily Update of Agriculture on WhatsApp**  
**+91-7900 900 676**

**DISCLAIMER:**

The information on this website does not warrant or assume any legal liability or responsibility for the accuracy, completeness or usefulness of the courseware contents.

The contents are provided free for noncommercial purpose such as teaching, training, research, extension and self learning.

\*\*\*\*\* 😊 \*\*\*\*\*

*Connect With Us:*

